

# J1 Joey

## Task Support Vehicle

Patents Pending

Three models available with maximum operator elevations of 126", 162" or 192"

### CAPACITY

1,000 lbs. total vehicle capacity up to 126" elevation

- 300 lbs. operators compartment
- 500 lbs. front work platform
- 200 lbs. rear "hide away" tray

### WEIGHT

2,268 lbs. to 3,160lbs chassis only

### WHEELS / TIRES

#### DRIVE

(1)9" x 3" polyurethane

#### STABILITY Caster

(2)3" x 2" polyurethane

#### REAR Wheels

(2)8" x 3" rubber

### BATTERY COMPARTMENTS

J1-126 & J1-162: 29.1" x 7.9" x 30"

J1-192: 32" x 11" x 30"

### SPEEDS

24-volt ZAPI AC-0 travel controller with 4 operator selectable travel settings and turtle speed mode. Standard travel speeds are variable from 0 to 3.4 mph with a high speed option available or ground level travel of up to 5 mph. Lift speed up to 42 fpm.

### ELECTRICAL

24-volt AC system manages the vehicles' electronic power steering, acceleration, neutral braking and automatic speed reduction at height and during tight turns when cornering.

AC drive motor provides high torque throughout the entire drive range. The brushless design of AC technology drastically reduces maintenance and extends battery range. Lift and lower controls are single speed.

Zapi LCD dashboard display includes fault code, hour meter, battery state of charge, travel speed and drive wheel directional indicator. The Joey comes with an emergency power disconnect, key switch and horn as standard equipment.



J1-192

### MAST

Heavy duty I-beam design provides excellent stability at height. Steel mast channels and side mounted lift cylinders increases platform capacity.

### CHASSIS

Three point chassis design with along with 180° drive motor steering arc provides exceptional maneuverability. Powerhead mounted stability casters add additional truck stability and operator confidence at working heights of up to twenty feet.

### OPERATOR COMPARTMENT

Ergonomic fingertip control for travel, lift, and lower functions provide the operator with logical intuitive drive characteristics while traveling at elevation or lowered.

Roomy operator compartment is designed for productivity. Large storage compartment allows storage of clip boards, pens, and miscellaneous fulfillment tools. Retractable compartment side-rails with audible alarm when raised.

### REGENERATIVE BRAKES

Regenerative braking is applied when the operator removes their hand from travel control or when travel speeds are reduced, Electromagnetic parking brake is applied after the truck is stopped.

### STANDARD FEATURES

- Electronic power steering
- Hide away rear work tray
- Front and rear flashing light
- Battery compartment rollers

### OPTIONAL EQUIPMENT

- Anchor w/tether and harness
- High speed travel
- Tow hitch (2,500lb tow capacity)
- 224AH AGM battery pack w/120v charger
- Industrial battery with external charger
- 12 volt power outlet adapter

### OPERATOR CONTROLS



Left Hand



Right Hand

### SEE THROUGH FRONT WORK PLATFORM



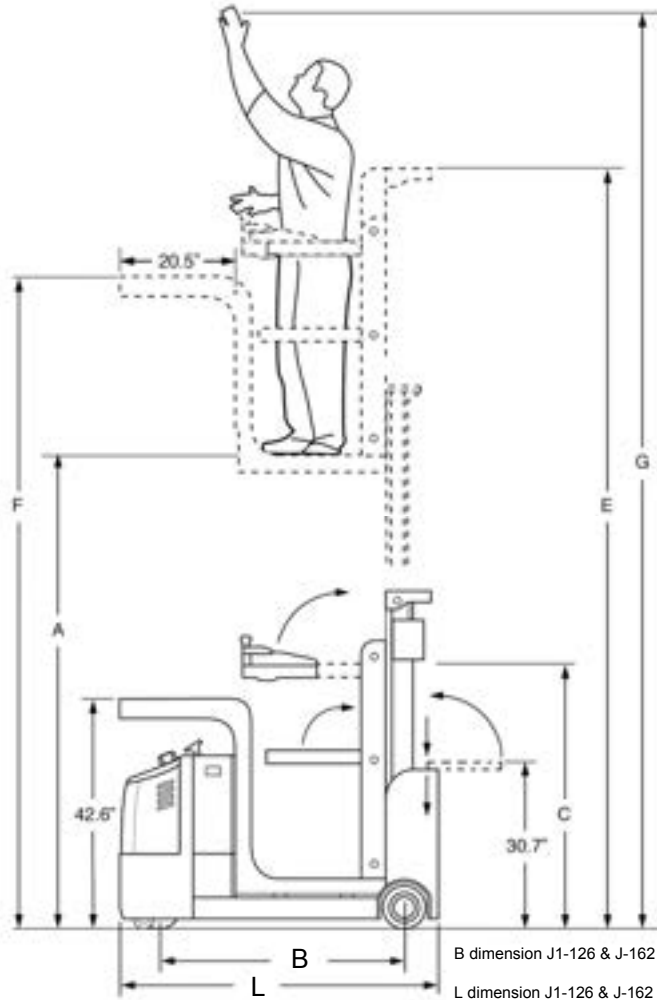

B dimension J1-126 & J-162 = 45.2", J1-192 = 49"  
 L dimension J1-126 & J-162 = 59", J1-192 = 63.25"

Turning radius J1-126 & 162 = 52.5", J1-192 = 56"

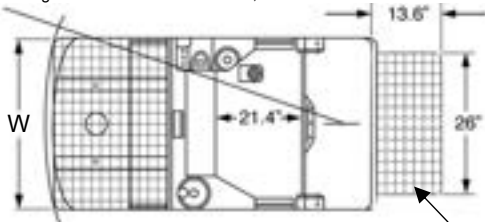

W dimension J1-126 & J1-162 = 31.5", J1-192 = 34" **Hide Away Work Tray**

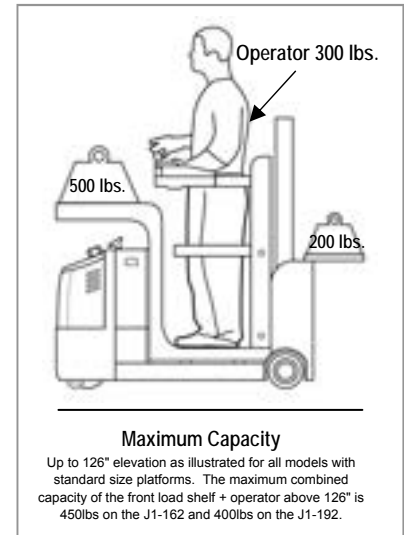
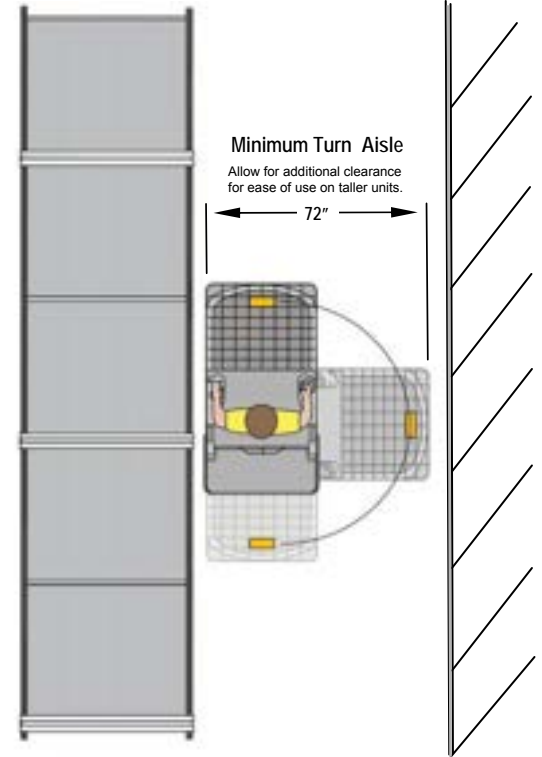

Model #	Mast	Lift Height	Col Height	Extended Height	Load Tray Height	Working Height	Weight Chassis Only
		A	C	E	F	G	
J1-126	Triple Stage	126	62.6	178.6	159.0	203	2268
J1-162*	Triple Stage	162	82.75	235.0	195.0	239	2610
J1-192*	Triple Stage	192	83.25	265.0	225.0	269	3160

\* Consult factory for derate

For indoor use only on level and smooth surfaces

**Certification**

Big Lift LLC will not assume liability for injuries or damage arising from, or caused by, the removal of any safety devices from their vehicles by user. Because of the Big Lift LLC policy of continuing product improvements, specifications are subject to change without notice. Rated Life: The lifespan of these vehicle models is ~4000 hrs or (8) years (whichever comes first) before end of life is advised.

© Copyright 2024, Big Lift LLC Printed USA 0524