

Worktable with Tubular Base

ASSEMBLY INSTRUCTIONS

CAUTION

INSPECT CONTENTS IMMEDIATELY AND FILE CLAIM WITH DELIVERING CARRIER FOR ANY DAMAGE.

SAVE YOUR BOX AND ALL PACKING MATERIALS.

YOU ARE RESPONSIBLE FOR DAMAGE TO YOUR UNIT IF RETURNED IMPROPERLY PACKED.

Hardware:

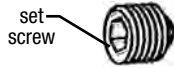

Hardware is located in plastic bag with brightly colored "HARDWARE ATTACHED" tape.

Tool required:

- 5/32" allen wrench



Step 1 - Assemble crossbrace subassembly.

- Assemble castings to end-to-end and front-to-back crossbracing, as shown.
- Tighten set screws* in the appropriate threaded hole in castings (see below).

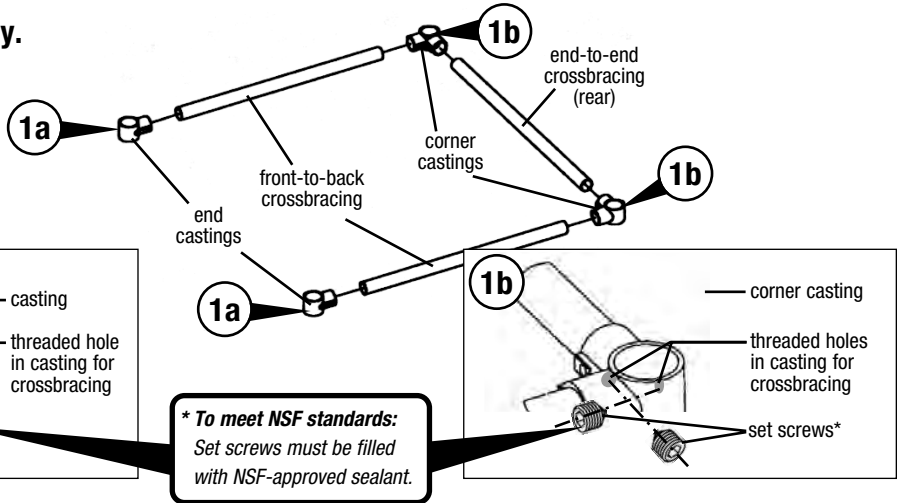

Please note:

Tables with six or more legs feature middle castings, additional crossbracing and additional end castings. For clarity, these instructions show assembly for a table with FOUR legs.

SUBASSEMBLY FOR TABLE WITH SIX LEGS

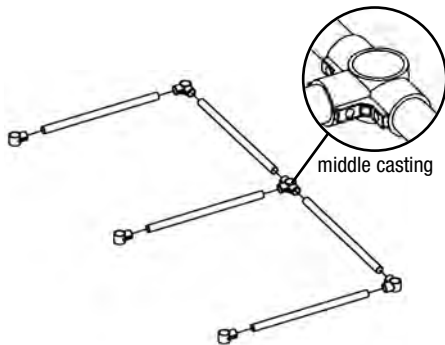

SUBASSEMBLY FOR TABLE WITH EIGHT LEGS

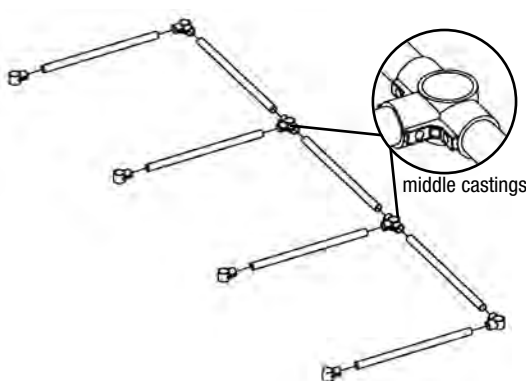

(continued on back page)

Worktable with Tubular Base

ASSEMBLY INSTRUCTIONS

Step 2 - Attach crossbrace subassembly to legs.

- On legs, measure and mark desired height* of crossbrace subassembly.
- Insert legs.
- Snug the set screws* in the appropriate threaded hole in castings (see below).

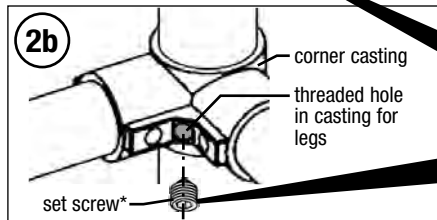
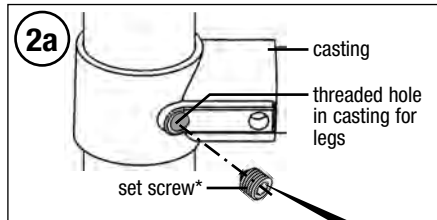

*** To meet NSF standards:**
Set screws must be filled
with NSF-approved sealant.

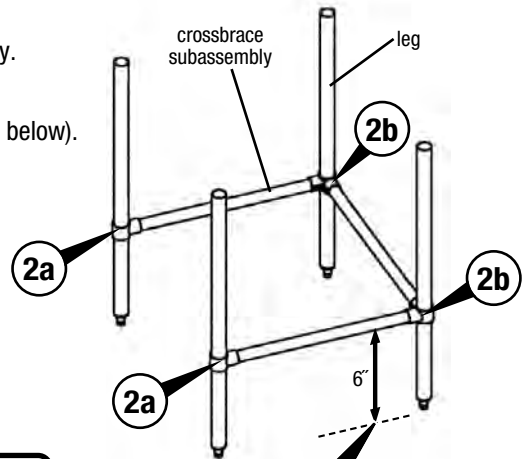

*** To meet NSF standards:**
Attach crossbrace
subassembly 6" from floor.

Step 3 - Attach tabletop.

- Turn tabletop upside-down (take care not to scratch the finish).
- Turn crossbrace subassembly upside-down and insert top of each leg into each tabletop gusset.
- Tighten all screws*.

*** To meet NSF standards:**
Set screws must be filled
with NSF-approved sealant.

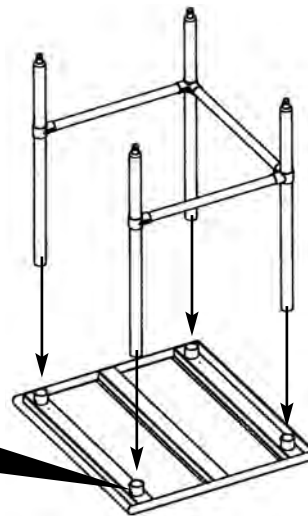
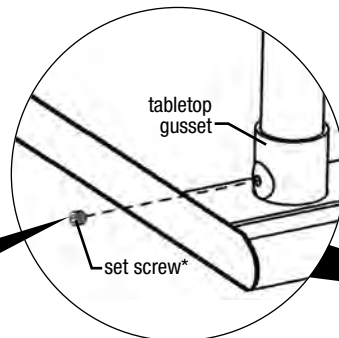

Assembly
is complete.

(End)



Level table with
adjustable feet.

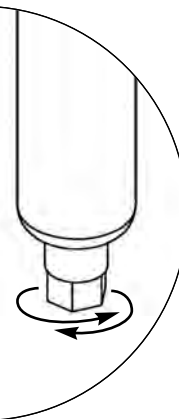

SOUTHWEST SOLUTIONS GROUP