

MODULAR OFFICE INSTALLATION INSTRUCTIONS

Introduction	1-2
Understanding the Drawing	3
Floor Track	4-5
Wall Erection	6-9
3070 Doors	10
6070 Double Doors	11
Windows	12
Electrical	13
Roof Deck	14
Non-load bearing beams	15
Load bearing roof	16-17
2-story Installation	18
Ceiling	19-21
2 and 3 wall units	22

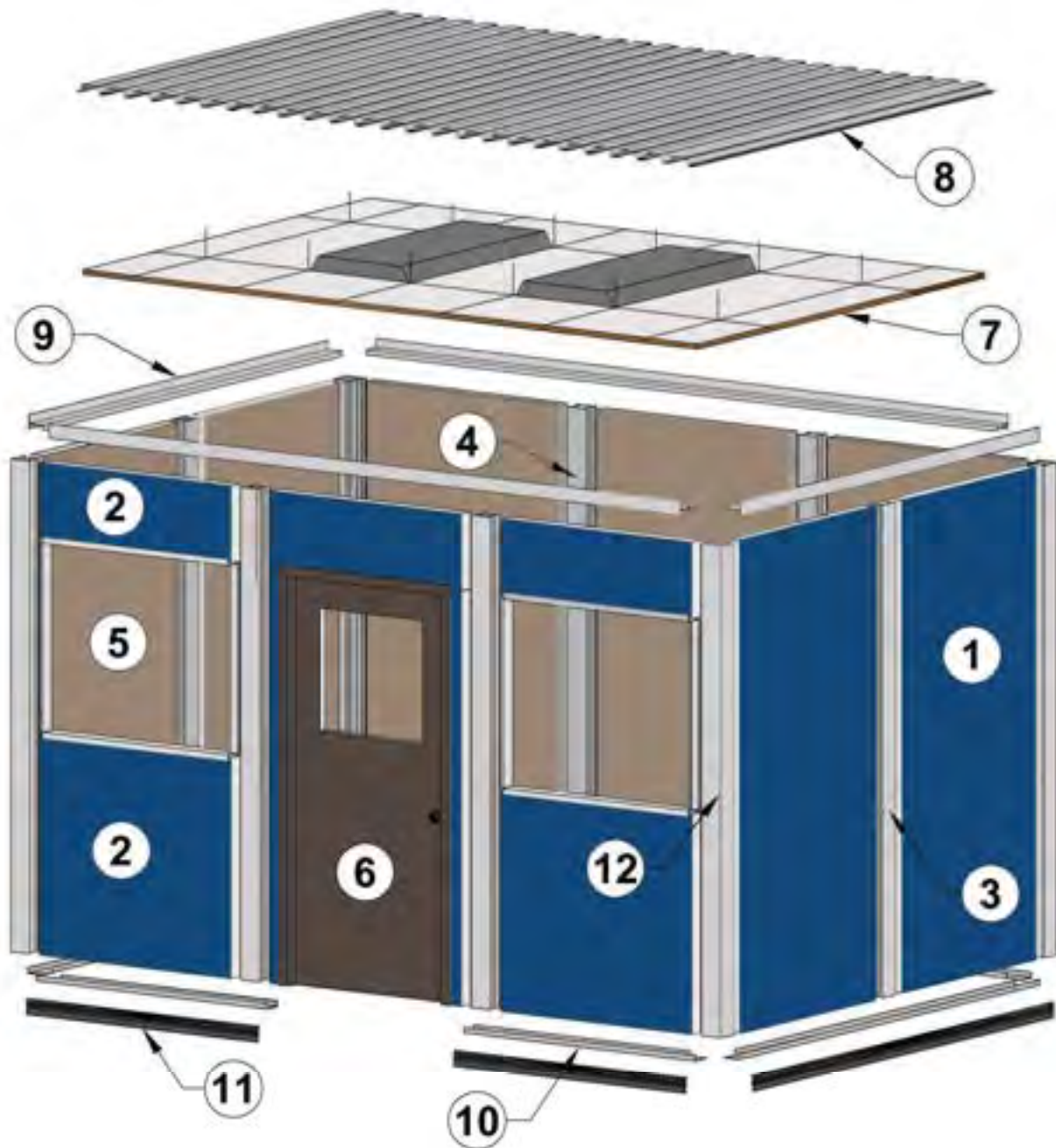

TYPICAL INSTALLATION



- | | |
|---------------------------------|-----------------------|
| 1. Solid Panel | 7. Acoustical Ceiling |
| 2. Upper and Lower Window panel | 8. Roof Deck |
| 3. Wiring Posts | 9. Ceiling Cap |
| 4. Wiring Post Cover Plate | 10. Floor Track |
| 5. Fixed Window | 11. Vinyl Base |
| 6. Steel Door | 12. Corner Post |

WE RECOMMEND YOU READ THESE INSTRUCTIONS THOROUGHLY PRIOR TO ASSEMBLY.

Your Inplant system is manufactured from high quality materials with care taken in handling and packaging at the factory. **Please inspect your materials and take inventory of all items to make sure damage or loss has not occurred in transit.**

Care must be exercised in handling these materials. Framing parts are made from aluminum or steel and while strong and durable, they can be scratched, bent or marred.

Due to varying floor surfaces we do not supply fasteners for the Floor Track.

For concrete floors we recommend:

1/4" x 1-3/8" RED HEAD WEDGE ANCHOR

We suggest the following tools to erect your Inplant system

Hammer	Metal Snips
Rubber Mallet & Wood Block	Power or Hand Saw
Drill, Bits and 5/16" Nut Driver	Hack Saw
Level	Pencil
Plumb Bob	Putty Knife or Trowel
Chalk Line & Dry Line	Ladder
Tape Measure and Rule	Pop Riveter
Phillips Screwdrivers	Power Metal Saw
Standard Screwdrivers	Carpenter's Square

UNDERSTANDING THE DRAWINGS

Below are sample drawings to illustrate the signs, symbols and measurements that you will see on the drawings for your Inplant system.

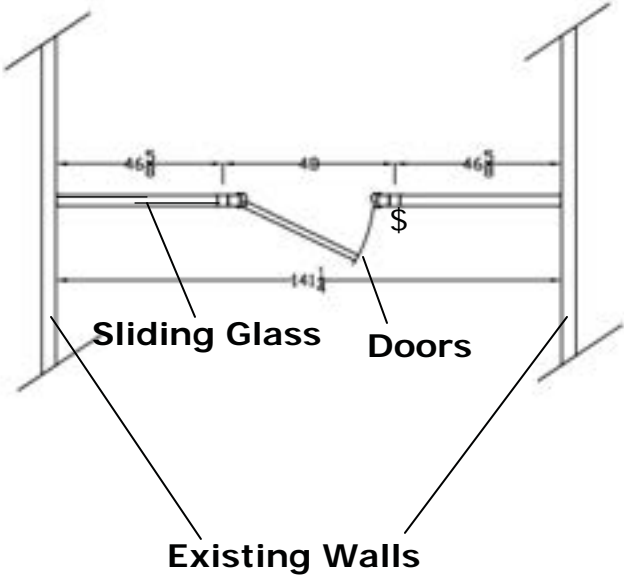
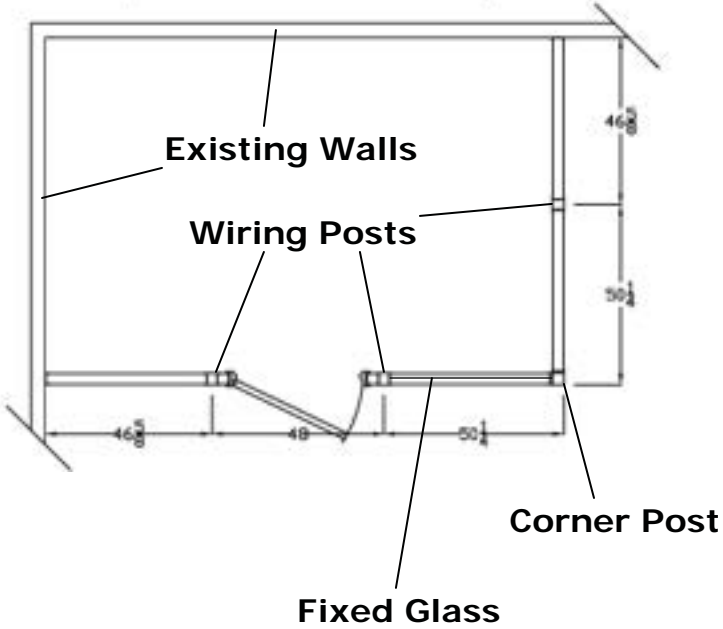
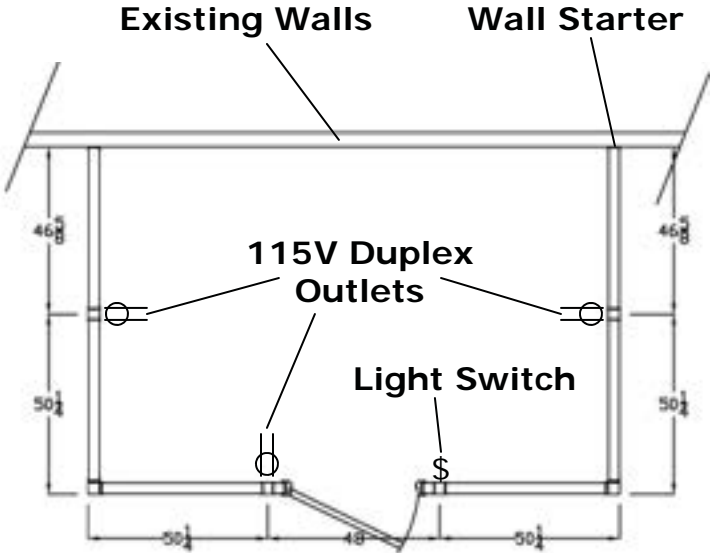
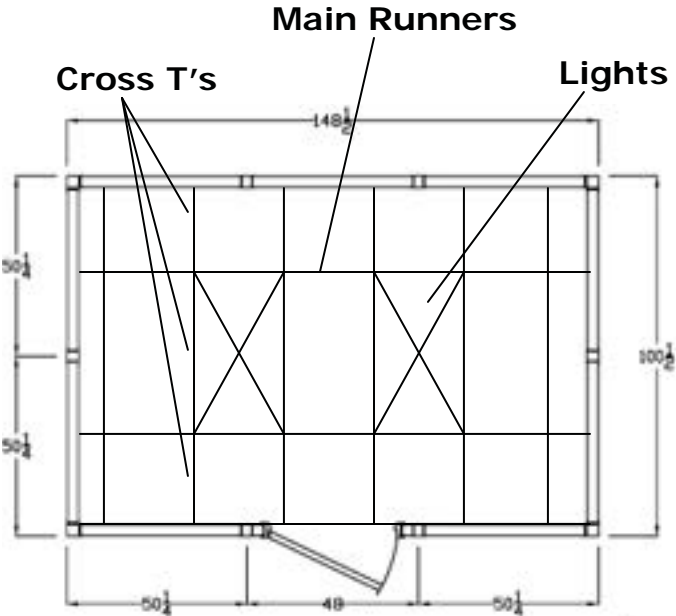

FLOOR TRACK INSTALLATION

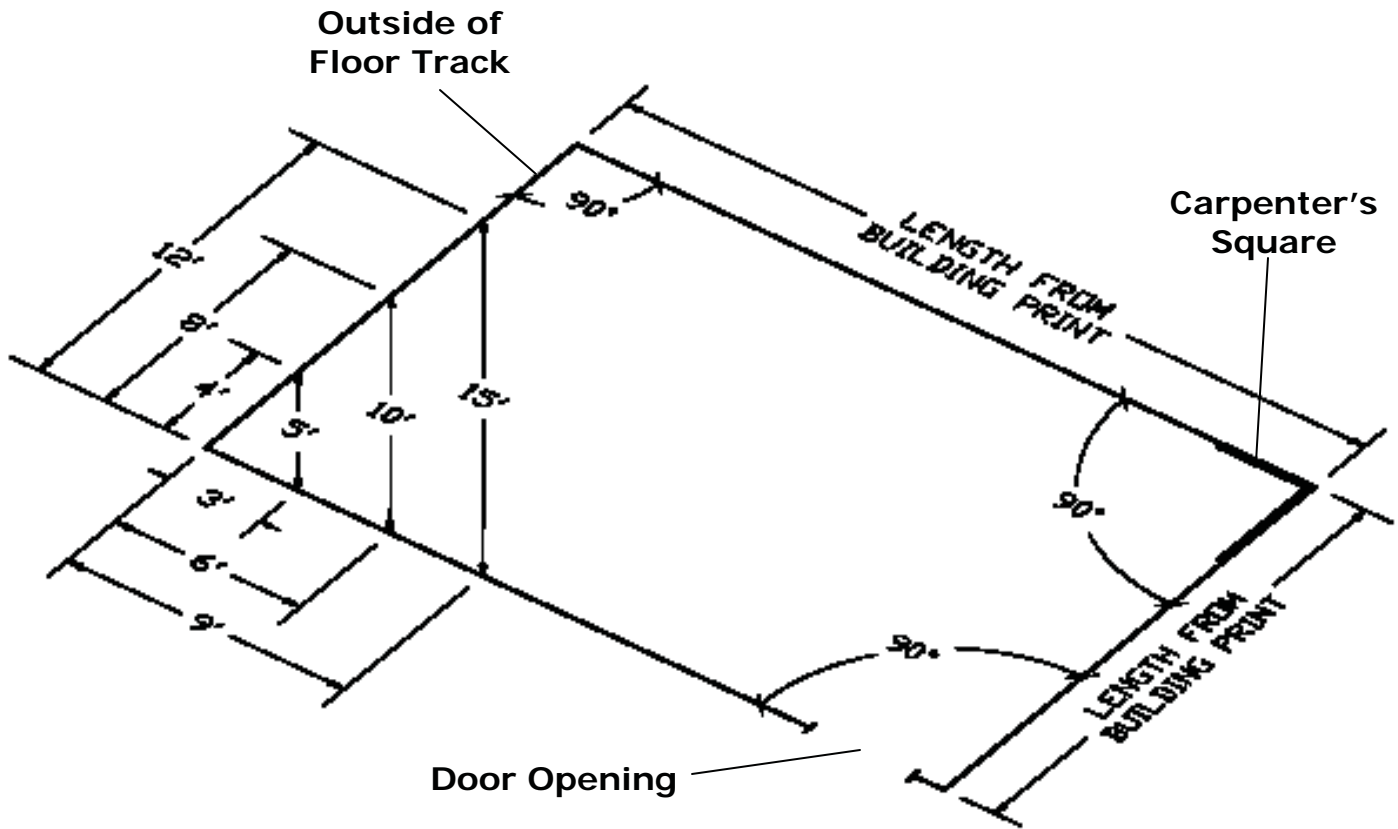

1. Locate your first wall and strike a chalk line on the floor. This line is the outside edge of your floor track.
2. Locate on this chalk line the location of your cross wall. Through this point, construct a 90 degree corner using the 3-4-5 triangular method as indicated on the sketch above. Strike a chalk line through these points to mark the outside of the cross wall. All corners must be at 90 degrees.
3. Complete the building outline in like manner using the building dimensions listed on the drawings for your Inplant system.
4. Locate door openings and mark the floor accordingly.
5. Cut the floor track to fit between chalk lines from one adjacent corner to the other. You will note that the corners will overlap.
6. Terminate the floor track at both sides of door openings.

*** Because of the variety of floor surfaces ***

*** We do not supply fasteners for the floor track ***

FLOOR TRACK CONTINUED

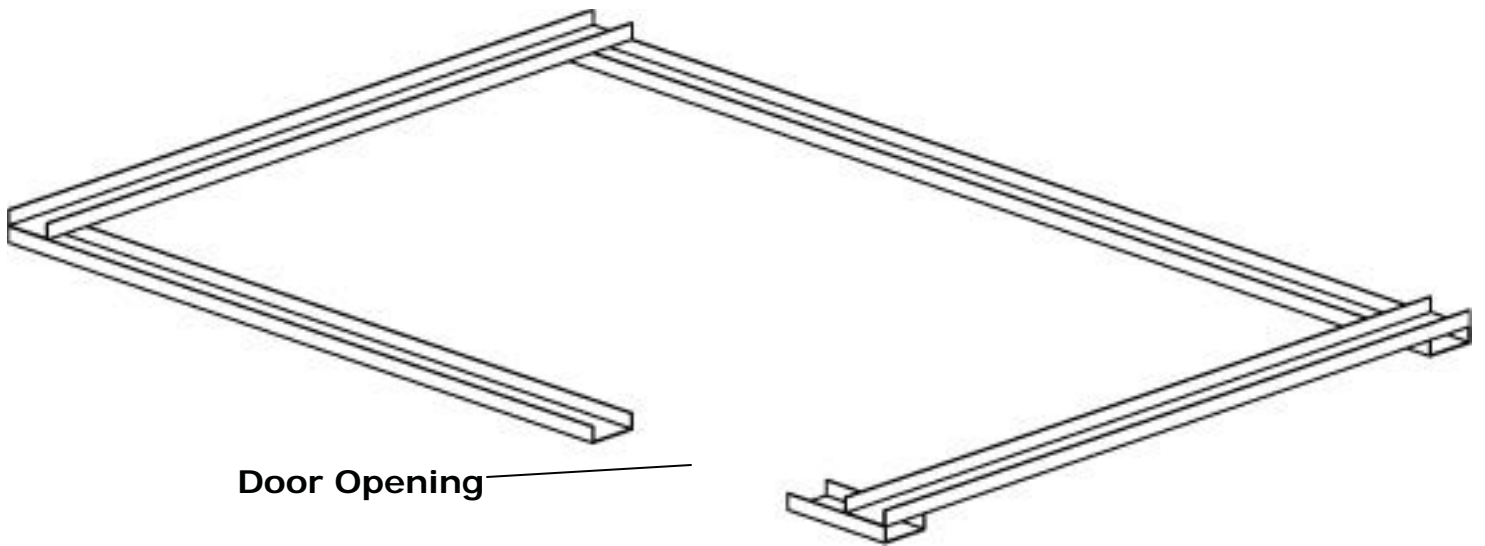

7. Now cut and notch the floor track at corner locations as illustrated below.

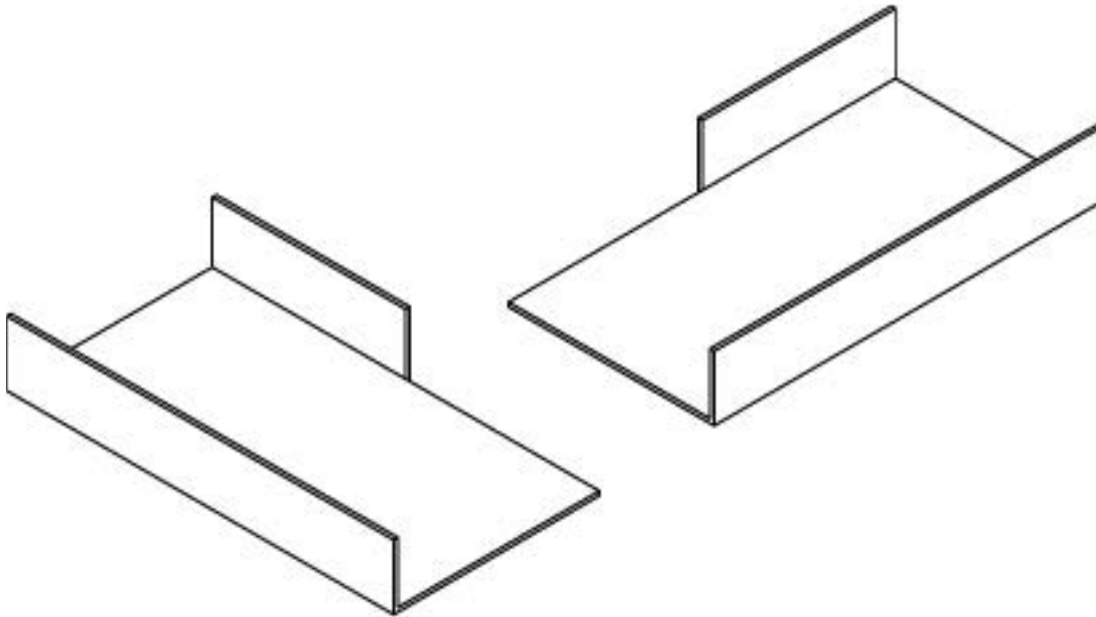

8. Anchor floor track using fasteners (not furnished) appropriate for field conditions and floor compositions. One fastener should be placed in each corner through the lap joint. Other fasteners should be spaced nominally 3' on center around perimeter, plus two on each side of door openings and at both sides of joints.

WALL ERECTION

The wall panels are fabricated ready to install in the wiring posts. All wiring posts and corner posts should be fastened loosely together with tek-screws on 24" centers. Be sure the two pieces of the wiring post and corner post are flush on the bottom before starting screws. Wiring posts and Corner posts, on all systems, fit inside the floor track.

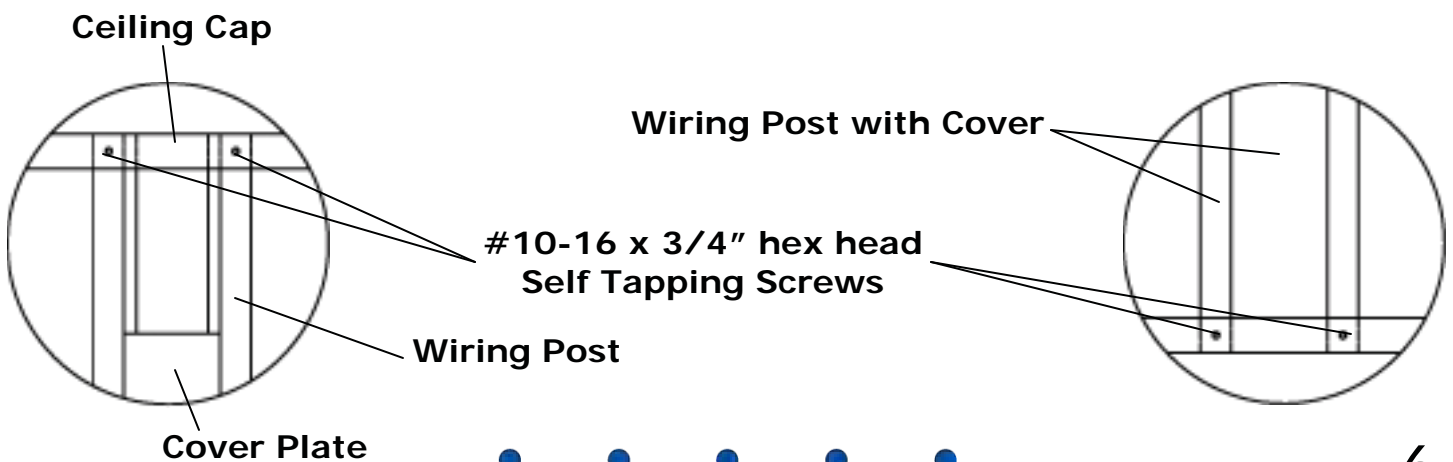
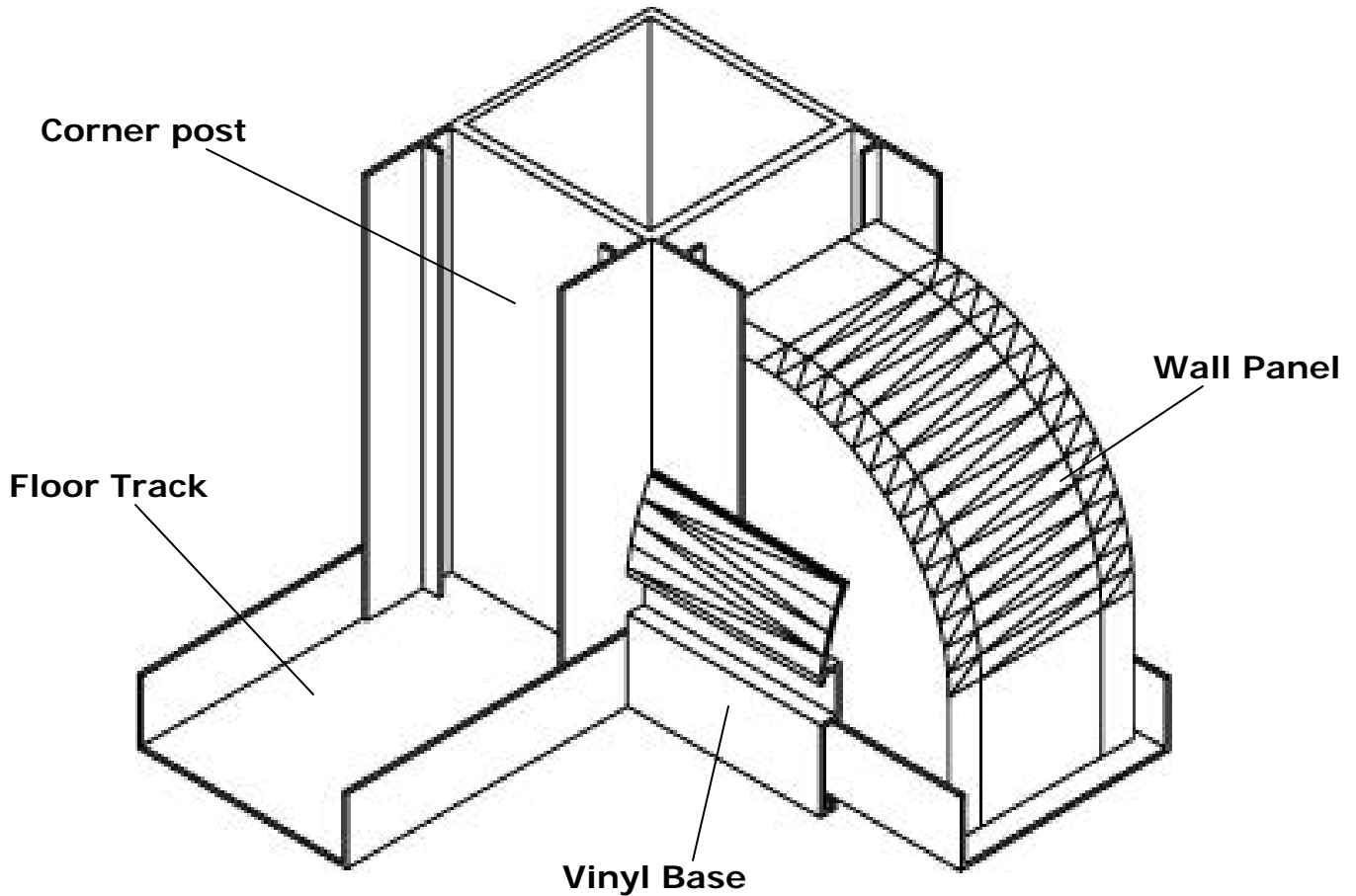

WALL ERECTION CONTINUED

Install the two adjacent wall panels into the floor track and slide into the corner post. Plumb the corner post.

Install mitered ceiling cap corners over corner post and wall panels to stiffen corners before proceeding. With each perimeter corner included in your unit, you will receive two pieces of ceiling cap mitered at 45 degree angles. These special pieces will be used to make your ceiling cap corners. Attach the corner connection together with a splice plate. The end that is not mitered should end up at the center line of a wiring post. If not, then field cut.

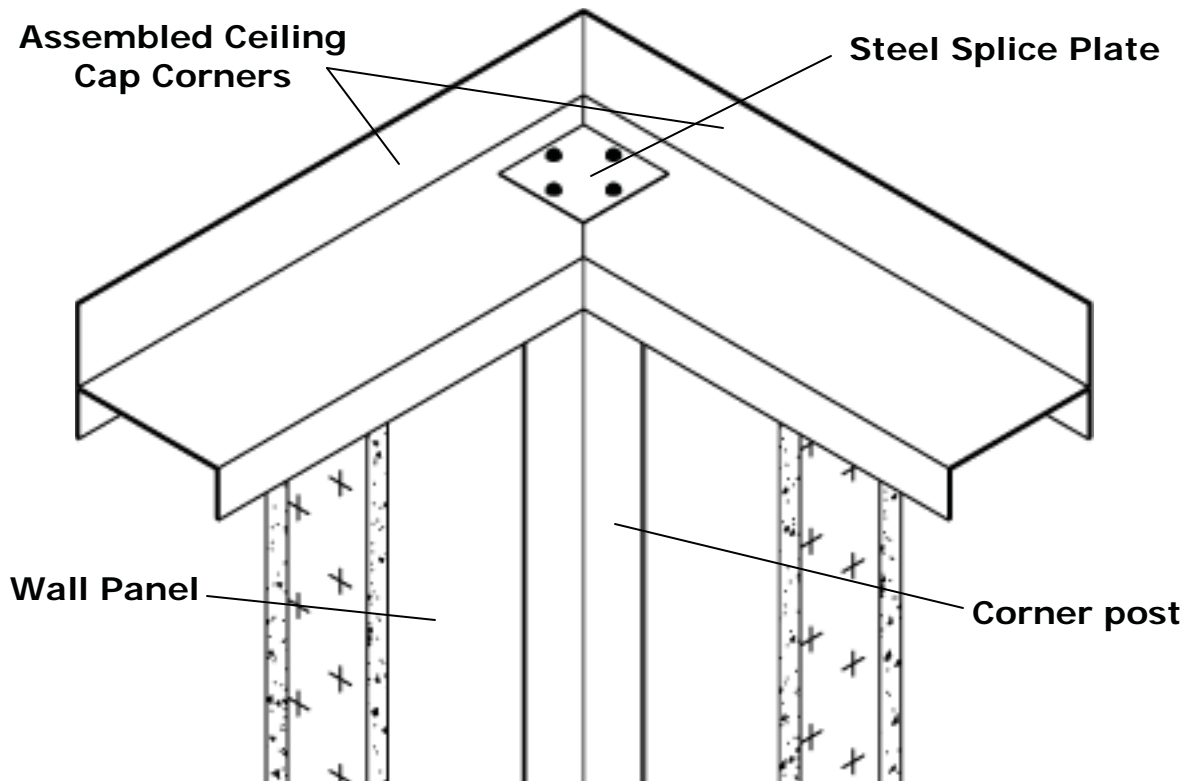

Continue along either wall by first locating center lines of wiring posts. These dimensions will be shown on the drawings provided for your system.

WALL ERECTION CONTINUED

Insert the next panel into the floor track and slide into the post. Then tighten the post screws. Proceed around the perimeter in the same manner. Install ceiling cap corners after each corner is in place and tightened. Check the centerline dimension of each wiring post with dimension on your drawings. This will eliminate any gaps or shrinkage of the overall dimensions. The last panel is installed by separating the wiring post and reconnecting after the last panel is in place.

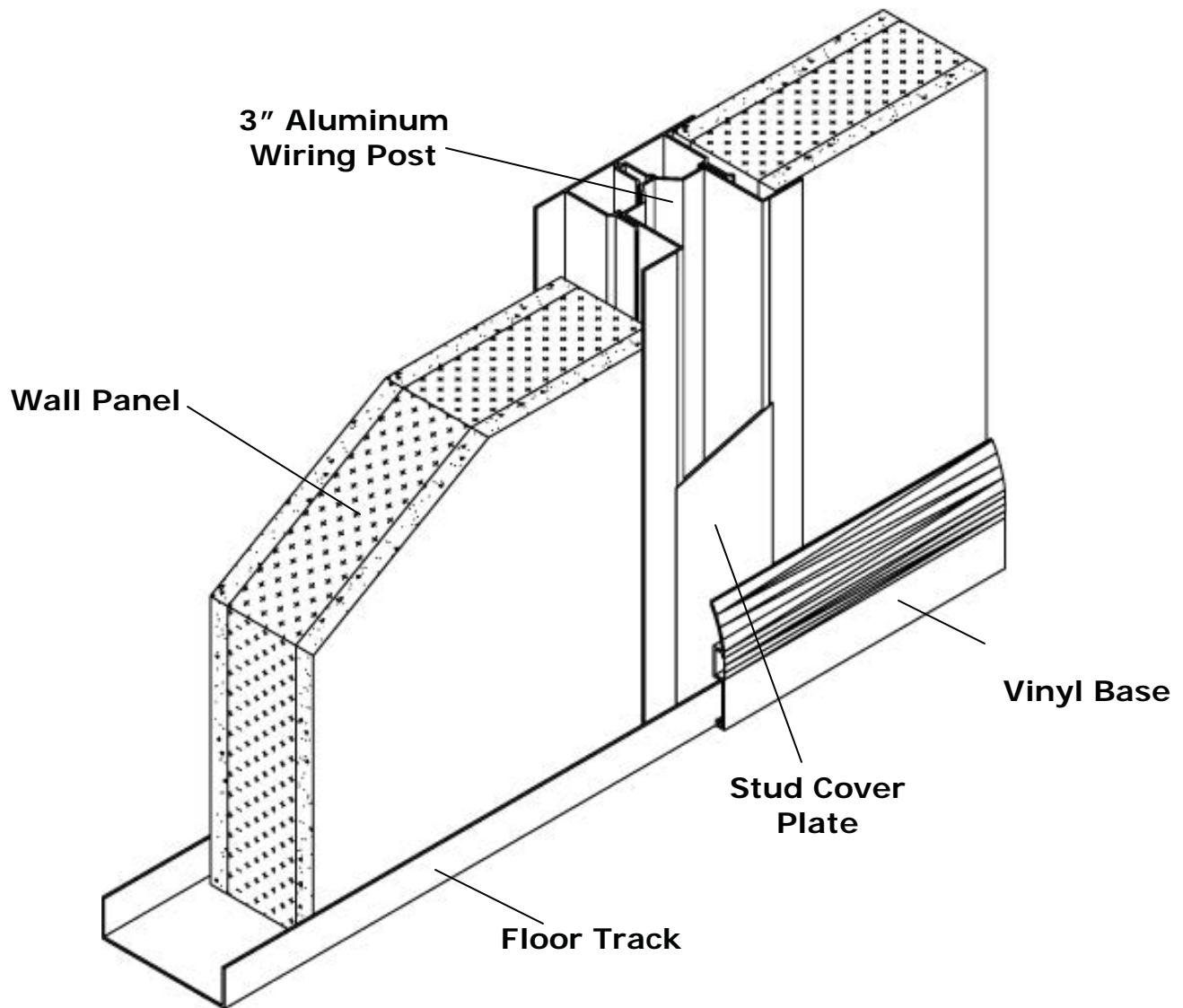

Note: For load-bearing or 2-story applications, Inplant Offices will provide a 14ga plate measuring 8" long by 3" wide to place inside the floor track under every wiring post.

WALL ERECTION CONTINUED

Check to make sure all corners are plumb. Now cut ceiling cap to fit between ceiling cap corners. It is very important that sections of ceiling cap intersect over wiring posts. Some field modification may be necessary.

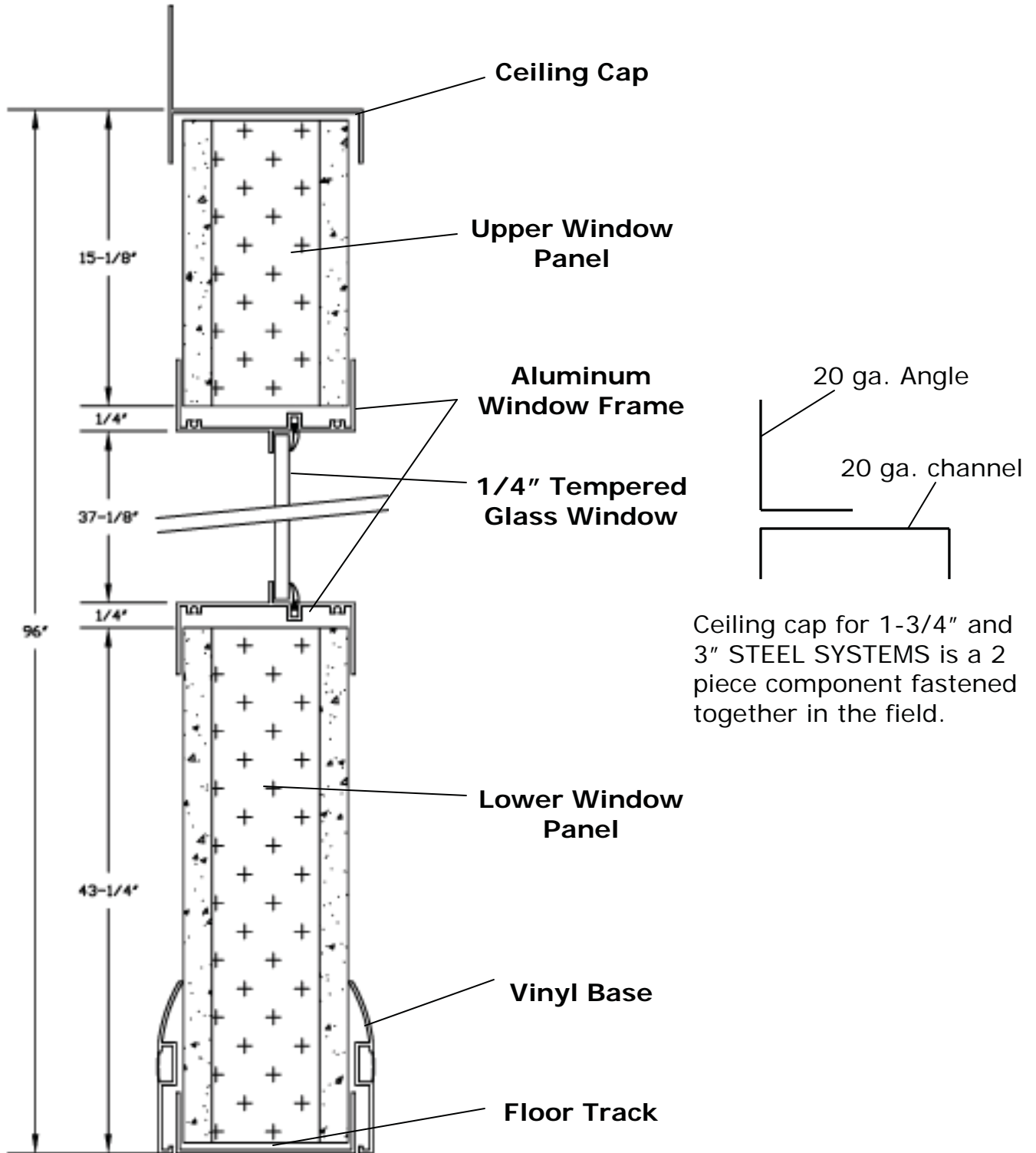

SINGLE DOORS

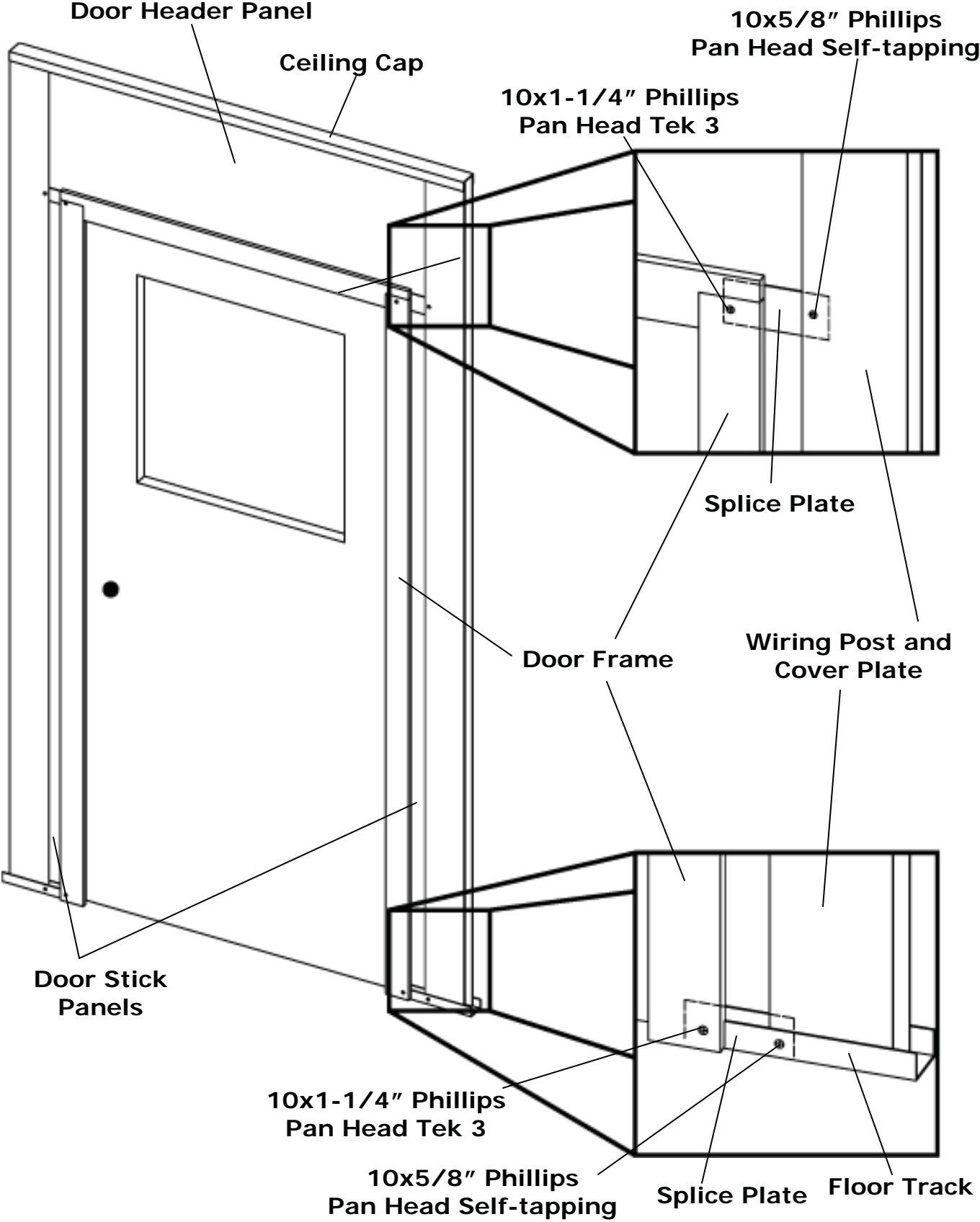

DOUBLE DOORS WITH STEEL FRAME

NOTES BEFORE INSTALLATION OF DOUBLE DOORS

1. Read all of the door assembly instructions prior to setting the door.
2. Assembly of posts and steel tubes must be completed at the time the door is being erected in the wall.
3. If floor is unlevel, work from the high side and shim vertical tubes so that the horizontal tube is level.

1. Locate and plumb wiring posts at the required 80-5/8" apart (centerline dimensions). Secure one of the posts to the floor track with a #10-16x3/4" screw.
2. Insert vertical 84-3/4" tube into the side of the post as shown; 3" side to be inserted into post.
3. Place the 77-1/2" tube horizontally on top of the two vertical tubes and you now have a 3-sided steel tube frame.
4. Install door header panel(s) by first attaching painted C channel upside down on top of horizontal tube. Then install panel(s) and the short wiring post. The short wiring post will rest in the C channel.
5. Install ceiling cap over the panel assembly. Finish remaining wall panels, roof deck and ceiling before going to step 6.

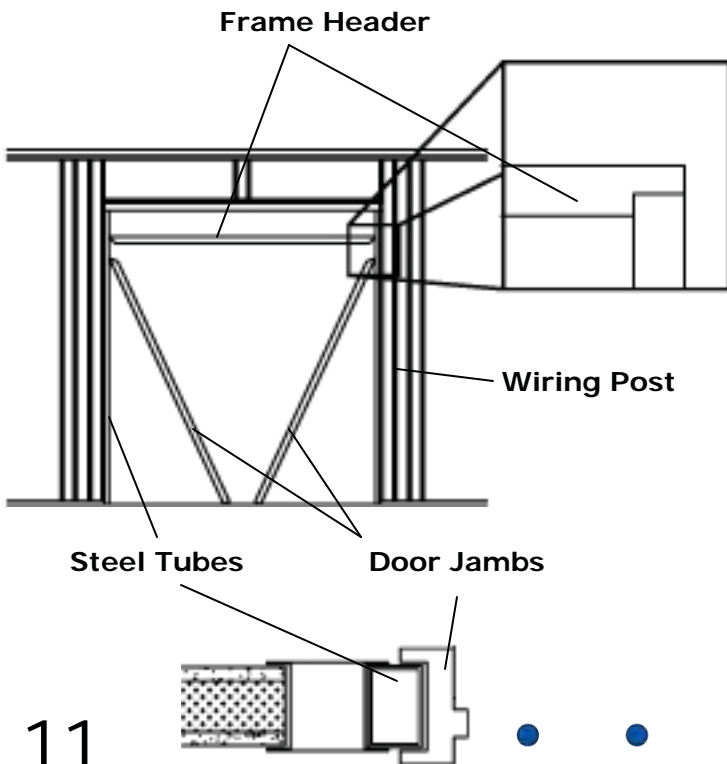
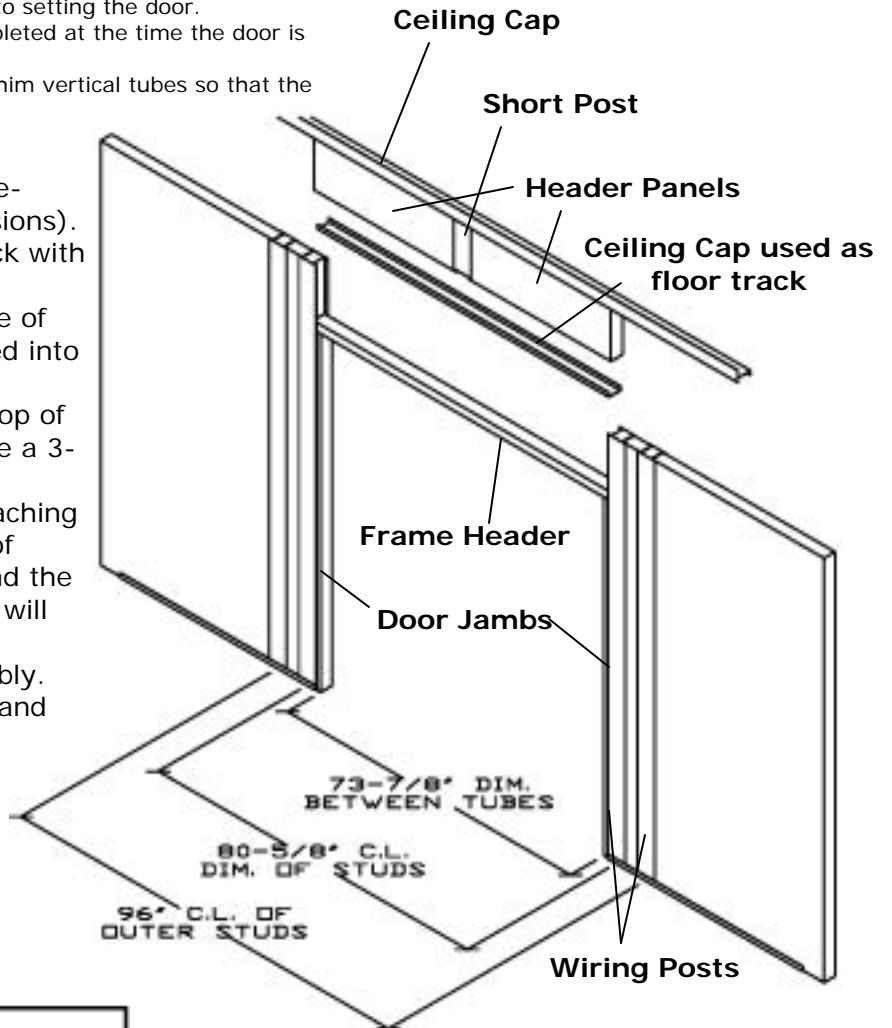

6. The door frame is a 3-piece knockdown frame. slide the door jam and header over the previously erected tube frame.

7. Attach doors to the door frame.

8. Plumb the door as follows:

- A. replumb the studs and tubes
- B. plumb one jamb and fasten at the header
- C. verify that the header is level, plumb the other jamb and fasten to the header

9. Once the door is plumb, secure floor track, post and tube together with #10x1-1/4" pan head screws on each side of studs (pre-drill tubes).

10. Secure door frame to tubes with #6x1-1/4" bugle head screws in locations on each side of the door frame (pre-drill tubes).

11. Door assembly is complete.

WINDOW INSTALLATION

Window units consist of three parts:

1. Lower window panel
2. Pre-glazed framed window
3. Upper window panel

Windows slide into the wiring post in the same manner as the flush wall panels.

1. Insert the lower window panel in the adjacent wiring post.
1. Install framed window component. Remember this unit is glass and is fragile.
2. Insert the upper window panel.
3. Slip on adjacent wiring post and proceed to next panel.

For proper installation, make certain that the window frames are inserted all the way into the wiring posts and sill heights align. If you have a wall consisting of all window units, it is imperative that the windows be pushed all the way into the wiring posts. Otherwise, the wall will grow in length and you will be unable to fit the last unit in that run. Refer back to stud to stud dimensions on shop drawings.

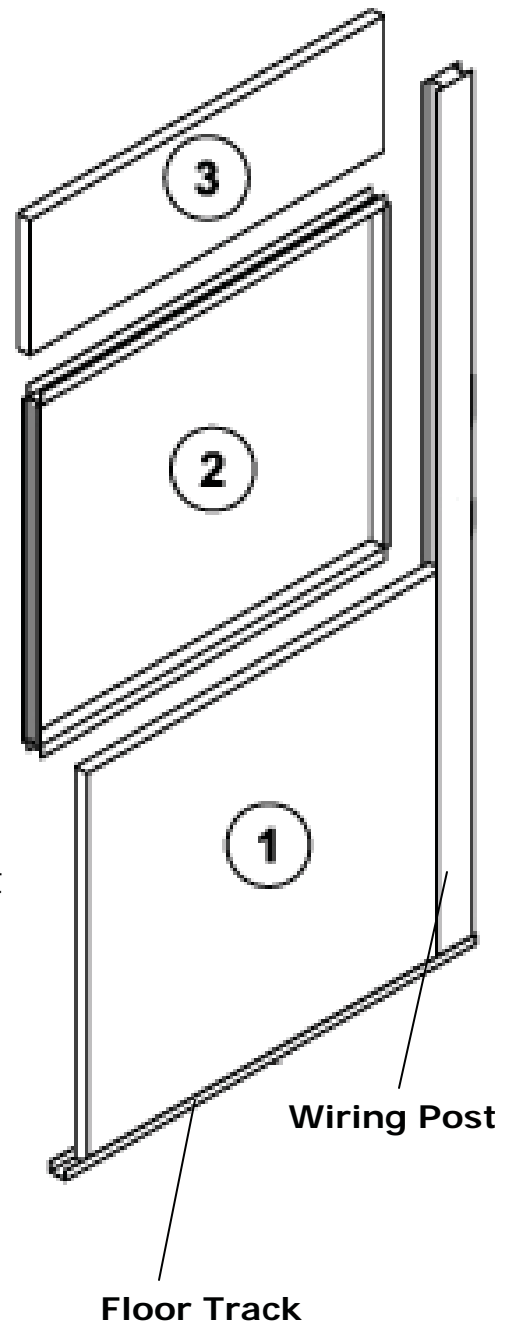

NOTES ON ELECTRICAL

Lights, outlets, switches, handy boxes, electrical cover plates, and load centers are included in a Standard Electrical Package.

Conduit and wiring is not furnished by Inplant Offices.

The wiring posts are designed to route data cables and electrical conduit and to receive handy boxes.

When your building shell is complete, mount your electrical boxes and conduit in the recesses in the wiring posts. Terminate the conduit just above the grid ceiling.

Pull wire (not furnished) and complete electrical hookups. Now measure and cut wiring post cover to run from top of electrical boxes to 1/2" above the wall mold for the grid ceiling and from the bottom of the box to the floor. Slide cover behind wall mold and floor track and snap into wiring post.

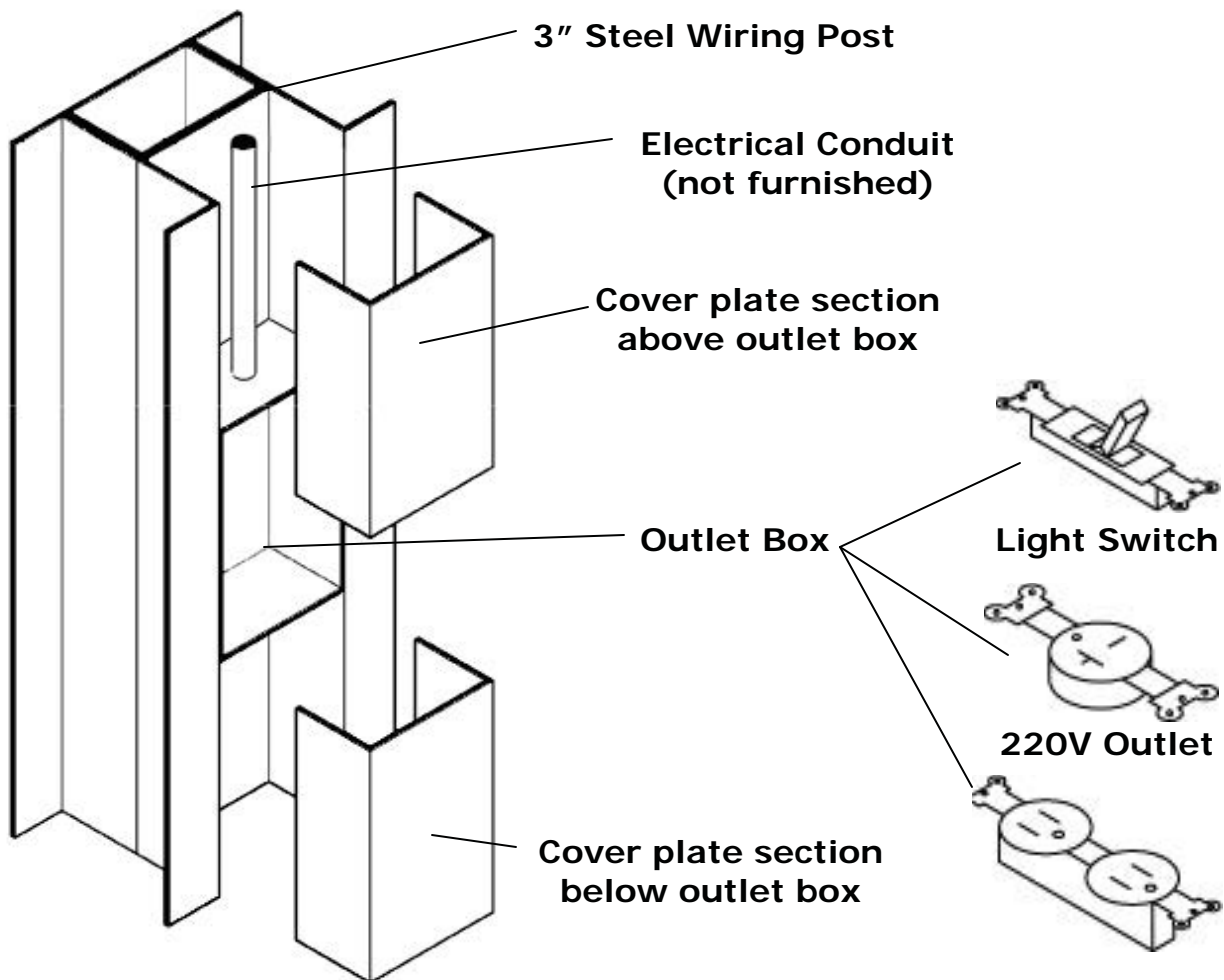

NON-LOAD BEARING ROOF DECK INSTALLATION

NOTE: ROOF DECK IS NOT DESIGNED FOR THE WEIGHT OF A PERSON OR FOR STORAGE.

Place caution stickers on trim angle on each side of building



The metal decking furnished to you is of the modified "V" roll-formed design. As such, it will grow or shrink in width during assembly. Care should be exercised to control the dimensions while erecting. Make sure that all walls are plumb as you begin fastening the roof deck to the ceiling cap.



In buildings with outside dimensions of 12'-4 1/2" or less in the short dimension, supplementary support members are not required. For these buildings, the decking will span from wall to wall.

1. Locate the first piece of decking starting at one end of the building.
2. Make certain that this first piece starts square with the building. Drill the deck and ceiling cap on the long side and screw together. Screws should be at each end and approximately on 18" centers in between.
3. Install the second section of decking in place by setting the valley on side "A" into the valley of side "B" on the previous piece of deck.
4. Screw the ends of the first piece of decking in the center of each valley into the ceiling cap. Also, screw the lap joint every 18" along the length of the decking.
5. Repeat these steps to complete roof deck installation.
6. Upon completion, all edges of the roof deck will be screwed into the ceiling cap in every valley and all lap joints of two pieces of decking will be screwed together on 18" centers.

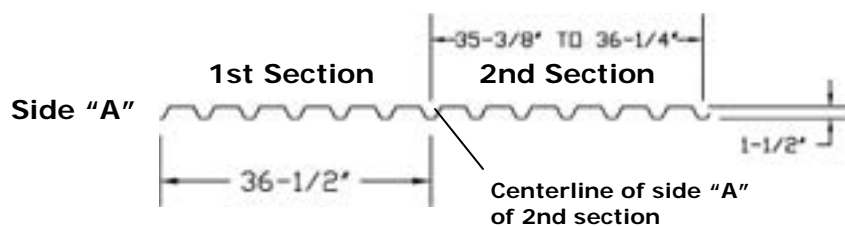

NON LOAD BEARING BEAMS

In buildings with the short distance greater than 12'-4 1/2", one or more support beams will be used. The metal deck will be fastened to support beams as outlined in the previous steps.

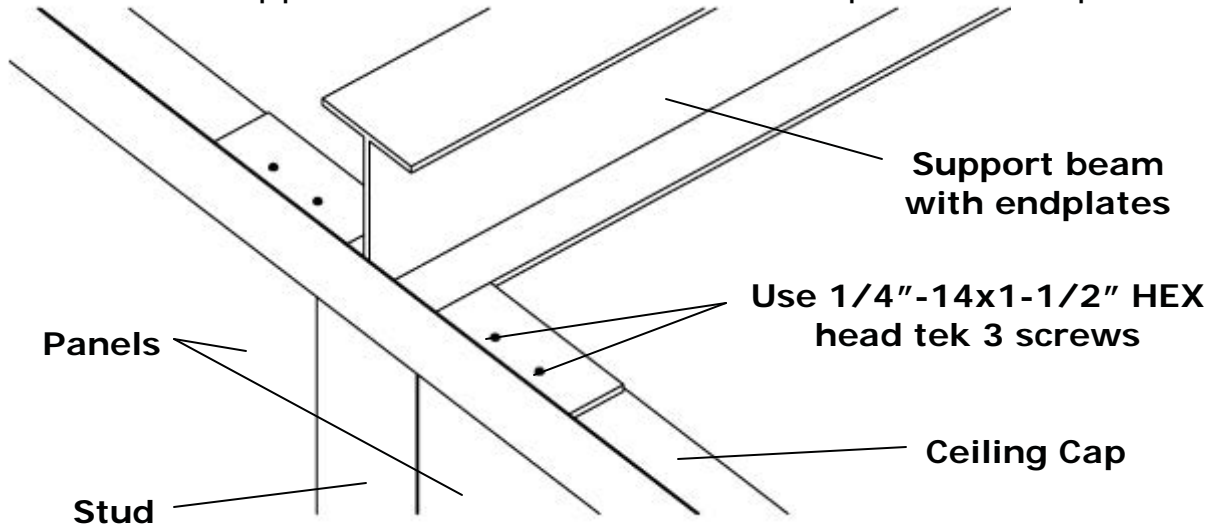

These support beams will rest on top of the ceiling cap. Drill 3/16" diameter holes, two on each side of the beam and attach to the ceiling cap with 1/4"-14x1-1/2" hex washer head self-tapping screws which are provided.

CAUTION: FOR SAFE INSTALLATION, ANCHOR DECK AS YOU GO. Also, work deck on both sides of the support beam to give even loading. For your safety, you must follow the above instructions.

Consult the drawings of your Inplant system for beam locations and install decking as you go.

IMPORTANT:
Place Caution Stickers on each side of building on trim angle.

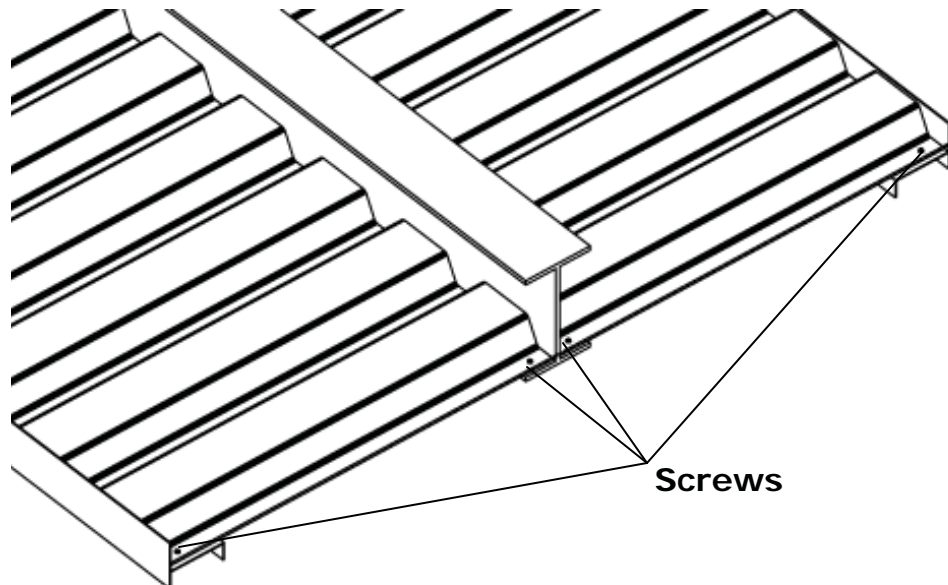

LOAD BEARING ROOF INSTALLATION

For load bearing and 2 story applications, the beams are heavier and mounted as shown below.

TOP VIEW OF STRUCTURAL SUPPORTS

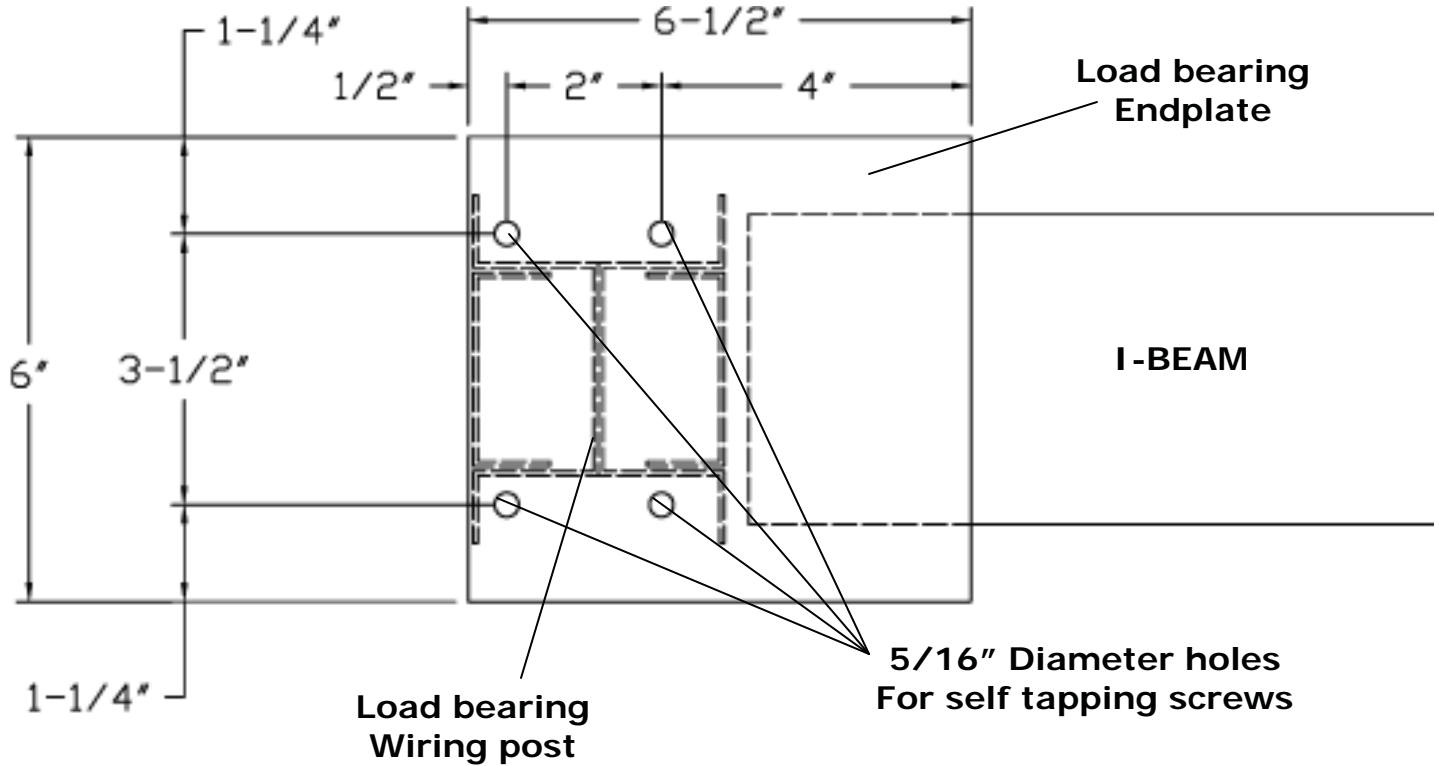

SECTION VIEW OF STRUCTURAL SUPPORTS

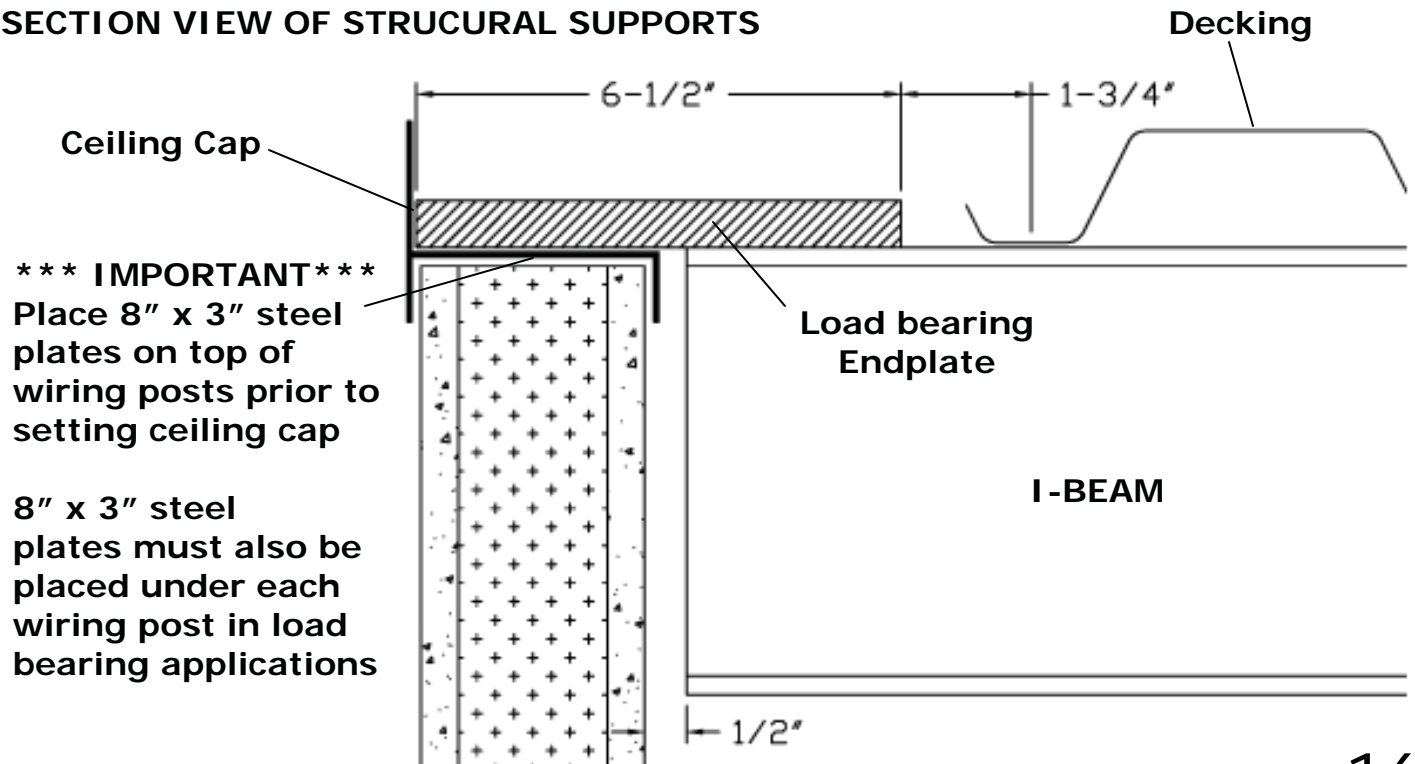

LOAD BEARING INSTALLATION CONTINUED

Structural Angle is used on perimeter walls running parallel to beams.

SECTION VIEW OF STRUCURAL SUPPORT ANGLE FOR 1-3/4" SYSTEM

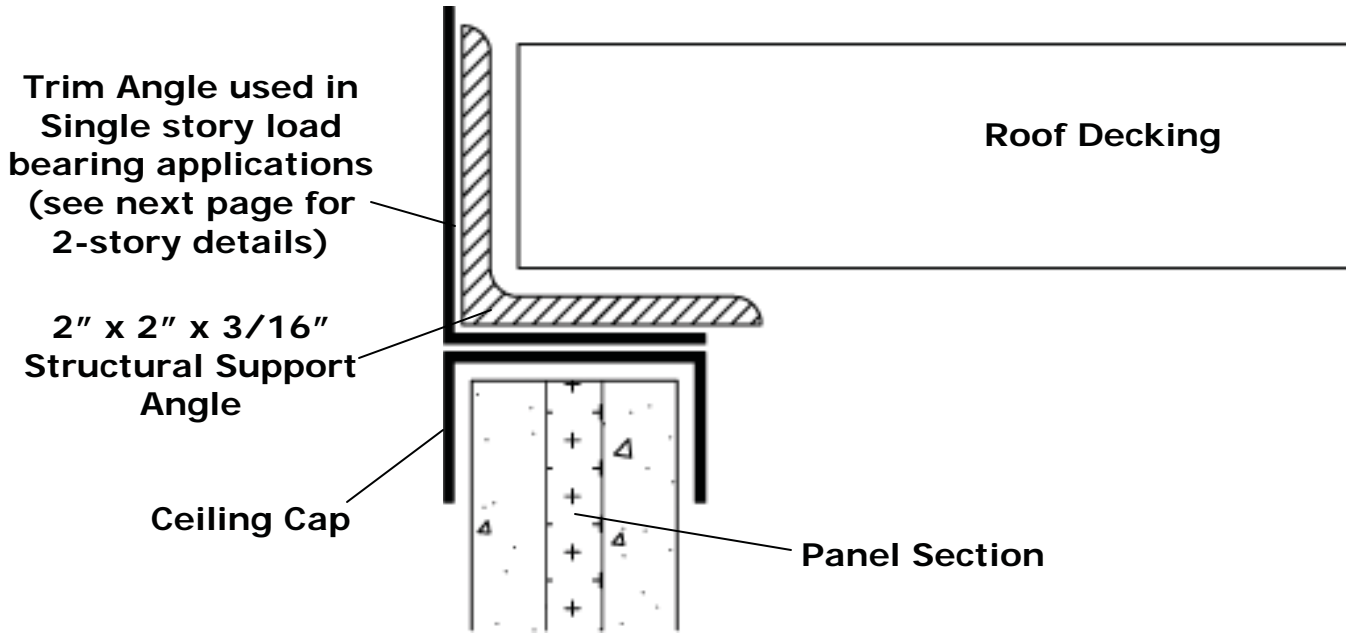

SECTION VIEW OF STRUCURAL SUPPORT ANGLE FOR 3" SYSTEM

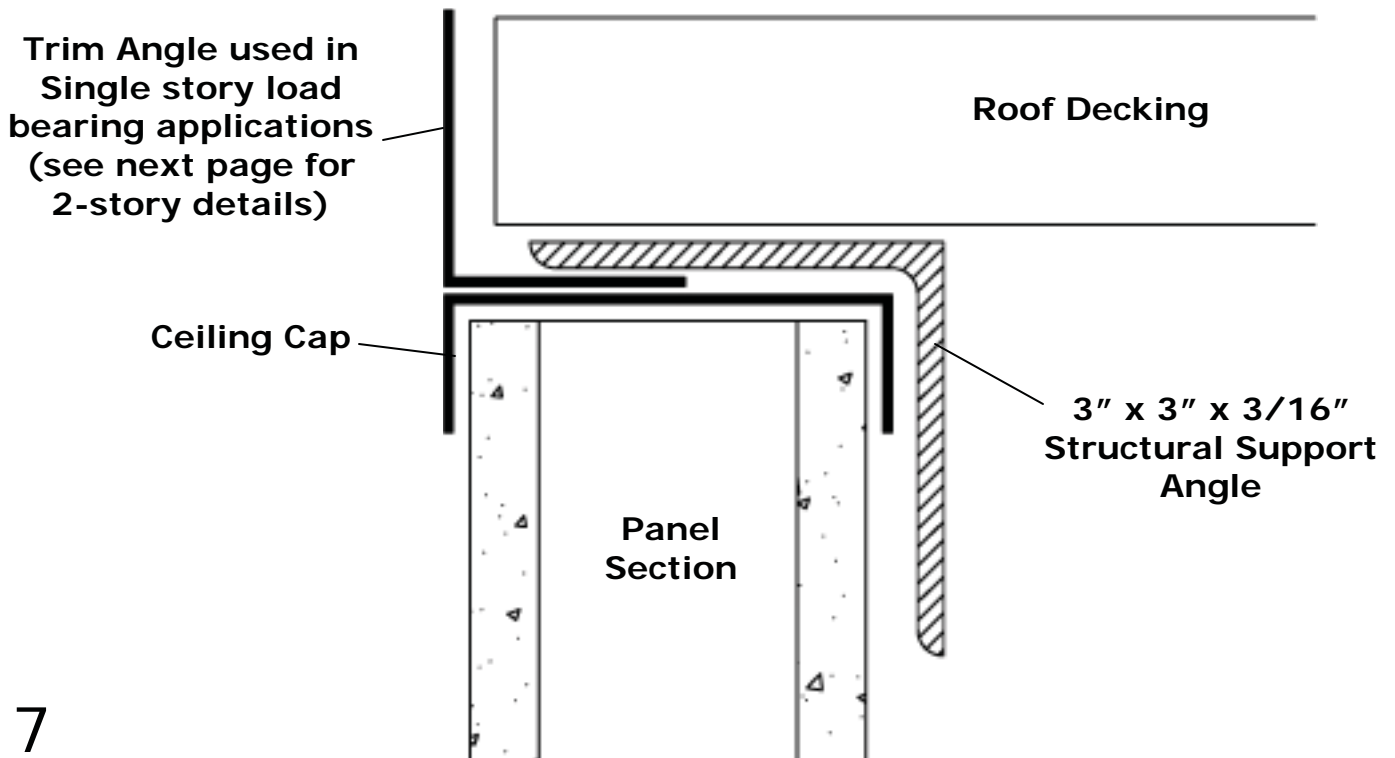

2-STORY INSTALLATION

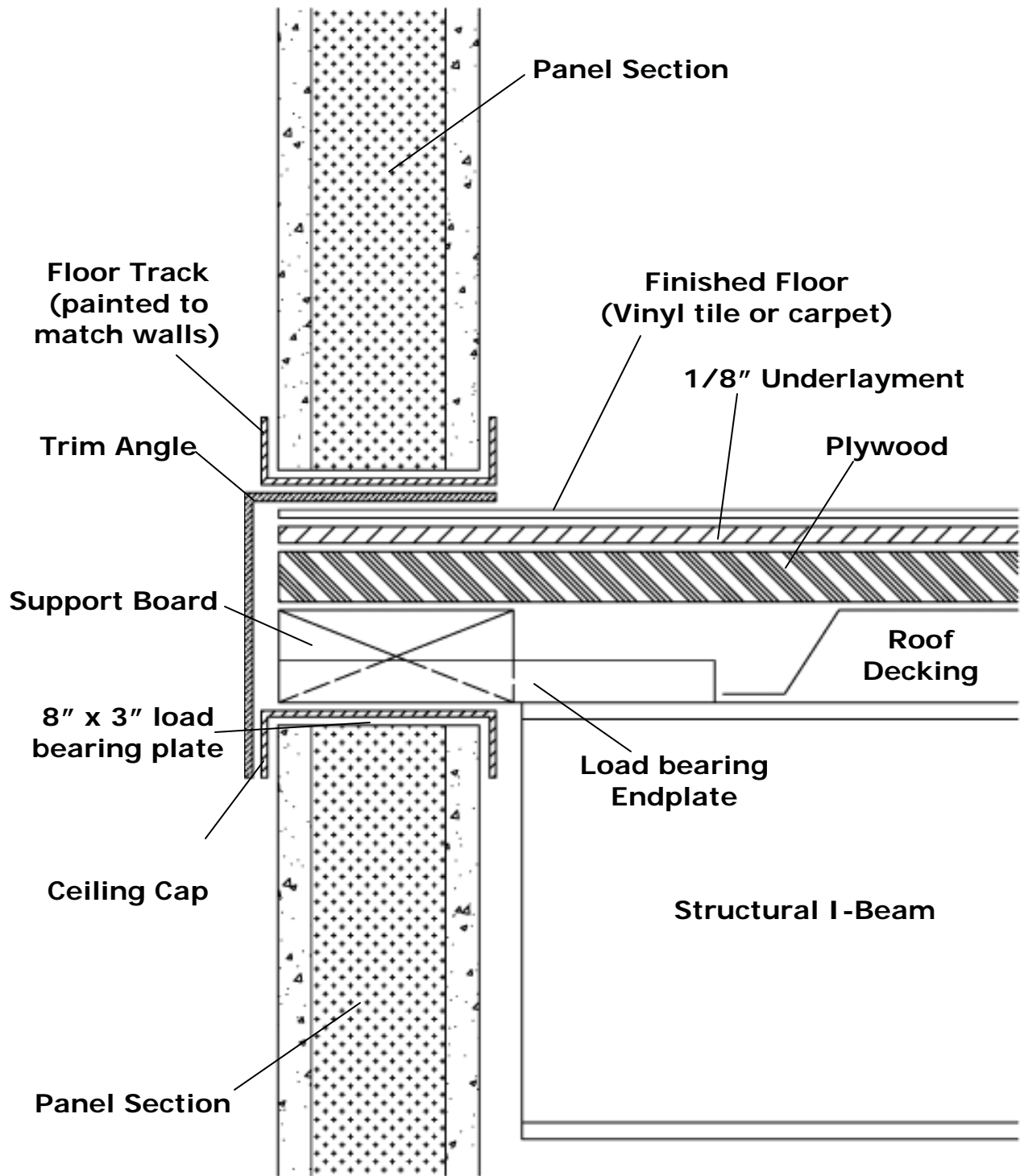

These heavier beams are supported by plates welded to the top of the beams. These plates rest on the ceiling cap and are attached with self-tapping screws. The roof deck must be attached to the support beams on 6" centers.

On the End walls where roof deck ribs are perpendicular to the walls, the 3-1/2" x 1-1/2" support board is omitted and the steel roof deck supports the plywood flooring of the second floor.

It will be necessary to attach a 1/4" underlayment to the plywood floor prior to laying a vinyl tile or carpet.

GRID CEILING INSTALLATION

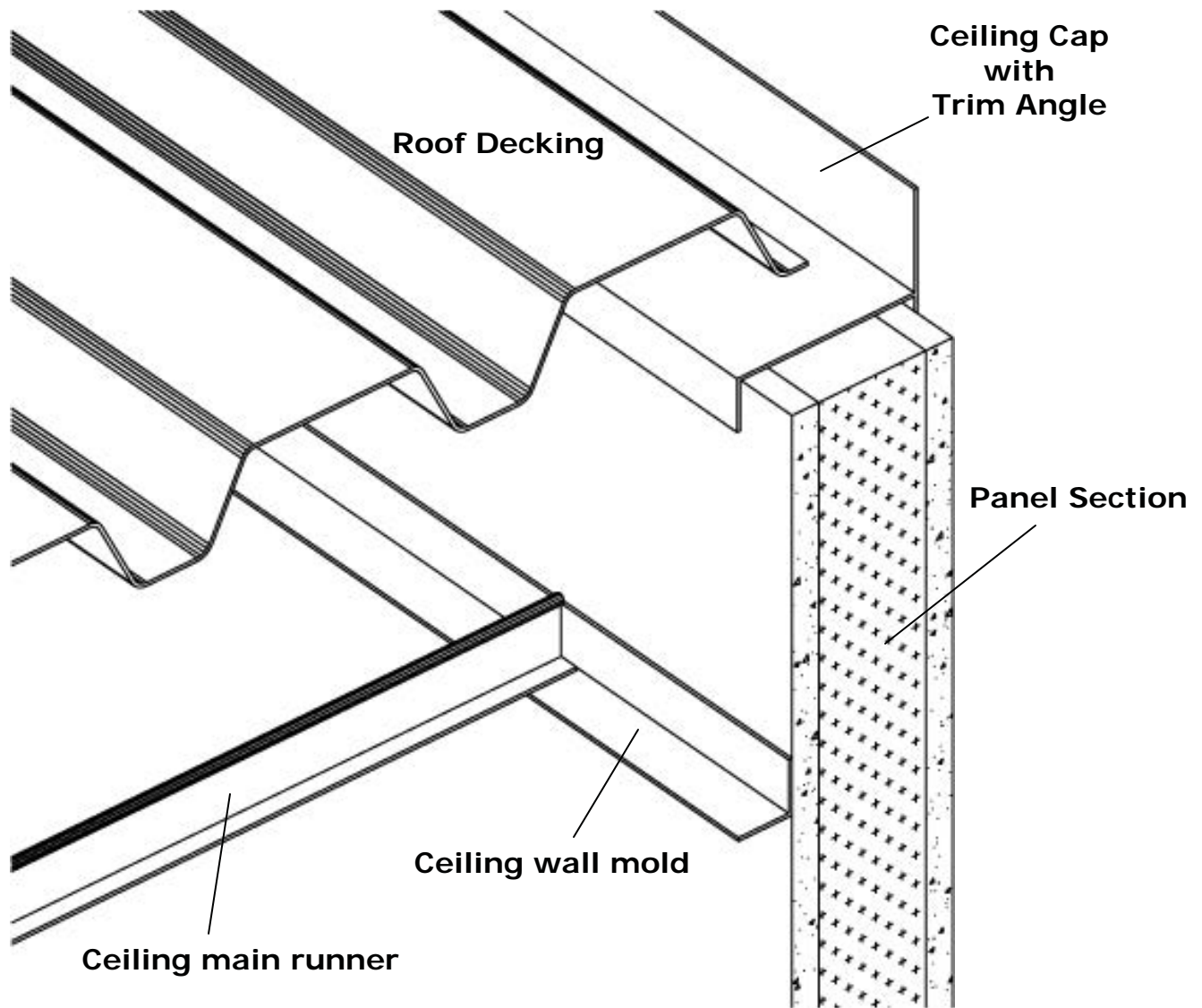

The standard ceiling furnished is the 2'x4' lay-in suspended grid type. The installation is similar to other applications of this type of system.

1. Determine the ceiling height. The ceiling may be set at any height to suit field conditions. Factory recommendations are that the height be no less than 6" from the top of the walls to provide adequate space for lights and insulation under the roof deck. After the ceiling height has been established, mark and snap a level chalk line on the walls for the room marking the location of the top of the wall molding.
2. Install wall molding making certain that the top of the molding is in line with the level chalk mark. For inside corners, lap one piece of molding over the other. Wall molding should be anchored with either sheet metal screws or pop rivets.

GRID CEILING INSTALLATION CONTINUED

3. Install main runners at locations shown on your drawing using the furnished hanger wire. Be certain that the first cross tee anchor points correspond to the building drawing. Install Eye-lags on the underside of the roof deck as required to suspend ceiling.

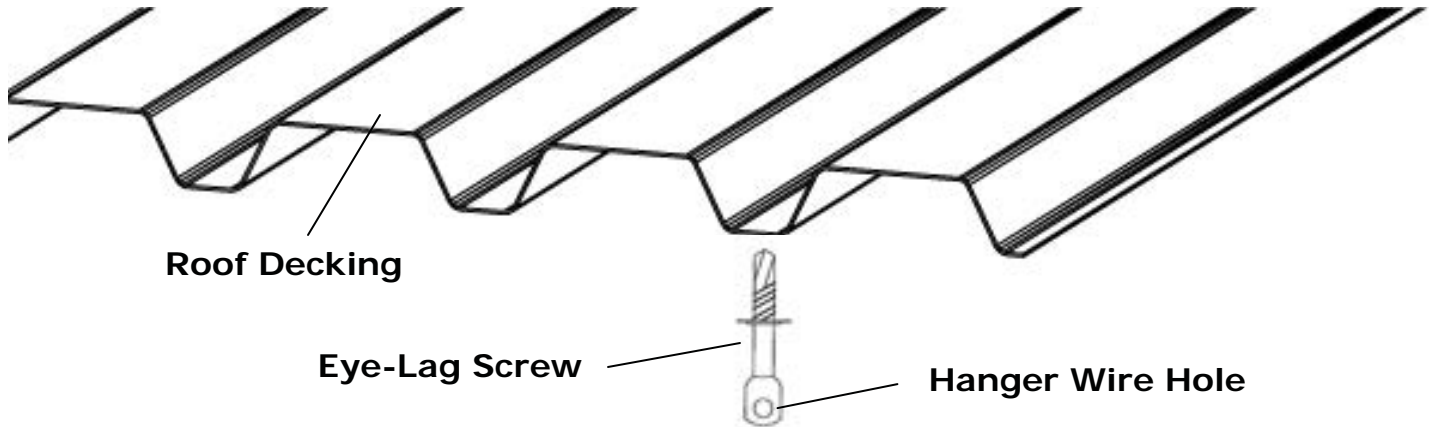

4. Attach ceiling hanger wire to eye-lags. Each full length main runner should be supported in at least 3 places by hanger wire. Make certain that a hanger wire is attached to each corner where lights will be located.

5. Install the main runner making sure it is straight and level. A chalk line stretched adjacent to the runner will facilitate this. It is necessary that cross tee anchor points align on all main runners. Standard main runners have 24 cross tee slots 6" on center starting 3" from the end. When joining main runners together, the 3" on each end maintains the 6" spacing.

6. If the ceiling has an odd sized border, the main runner must be cut. Measure from the inside slot nearest that measurement out.

For example (see below), if the border is 13-3/8", measure back from the slot just over 13-3/8", which is 15" in this case. Trim the main runner. After cutting to length, the tee slots will be correctly spaced.

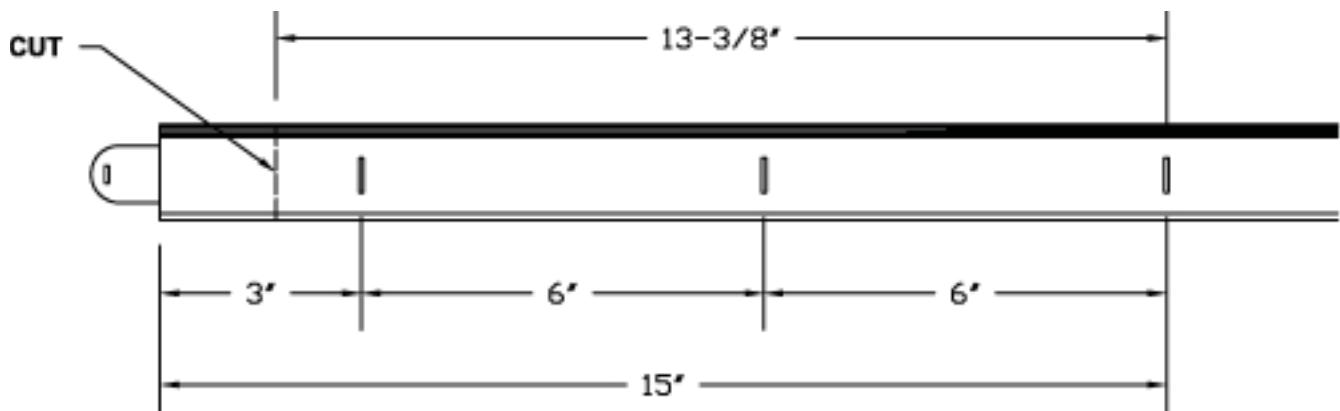

GRID CEILING INSTALLATION CONTINUED

The Main runners may be spliced together when spanning over 12' is required. Join main runners by snapping together making sure that the painted side of each runner corresponds.

7. Start the next row using the remaining piece of main runner by trimming the cut end so that cross tee anchor points align on all main runners.

8. Install cross tee's at points indicated your drawings. Intersections of cross tee's and main runners must form 90 degree corners.

9. Cutting ceiling panels may be accomplished with panel face up using a saw or sharp fiberboard knife. Measure and cut each of the border panels individually.

10. Install the ceiling panels. Lay-in panels are installed by resting these units on cross tee and main runner flanges. Exercise care when handling ceiling panels to avoid damaging the surface. Handle edges of the panels keeping the fingers, and particularly the thumb, off of the finished side of the board as much as possible. Clean handled area necessary for a clean job. Lay in the light fixtures in the same manner as the ceiling panels and the ceiling installation is complete.

BLACK COVE BASE MOLDING

Base mold is furnished for the exterior and interior of your Inplant system. The screw on base should be installed with the screws provided. Screws should be located a minimum of 24" on center, under the flap in the center groove.

ONE, TWO AND THREE WALL INSTALLATION

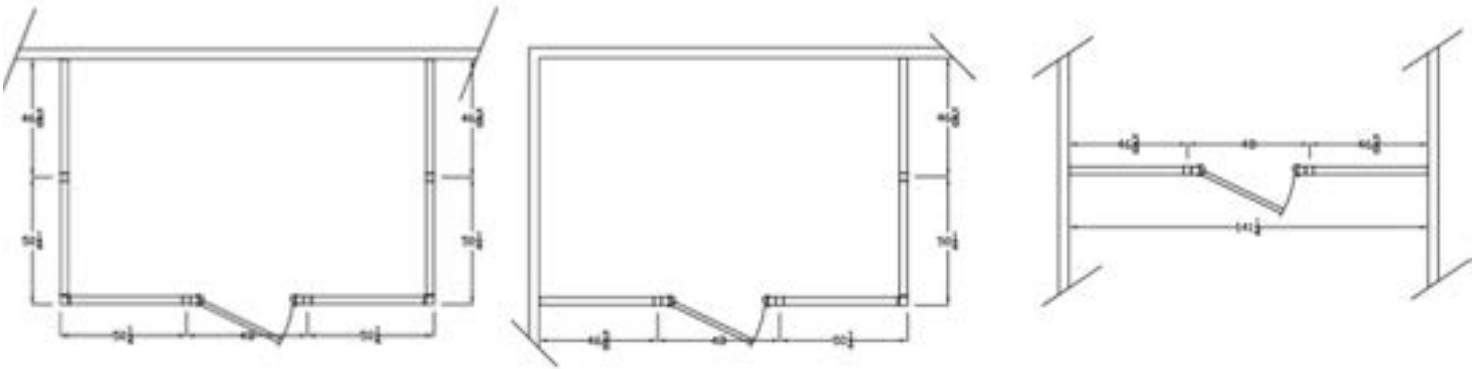

1. Strike a chalk line at a 90 degree angle to the existing wall at the point where the system is to intersect. This line will notate the outer edge of the floor track.
2. Locate the point on this line where the intersecting wall will connect. Refer to your drawings for exact dimensions. At this point, construct a 90 degree intersecting line.
3. Complete the outline of the building in similar fashion
4. Starting at the point located in step 1, install floor track as specified in standard instructions.
5. Cut and install wall starter vertically into floor track. Use anchors (not furnished) appropriate for field conditions and wall composition. If no shimming of panels is required, the length of the wall starter will be the same as the wiring post.
6. Install panels starting at the existing wall and the wall starter. Remember to hold the dimensions and centerlines as noted on your drawings.
7. For easy installation, install wall panels by working from each existing wall with the door being the last portion of the wall to be installed.
8. Structural steel angle is provided to support the roof decking along existing walls. Beams, if required are installed per the standard instructions.