

High Density Sliding Floor Track System



High Density Sliding Track System offers a unique way to maximize and efficiently move wire shelving systems. The patented design allows for quick and easy installation. Bearings in the skate are located under each post for a load capacity of 1,500 lb. per shelving unit. The v-groove floor track allows the shelving unit to slide back and forth with ease. Layout assistance is available.

PERFORMANCE FEATURES AND BENEFITS

- Low shipping cost
- NSF approved
- Uses industrial bearings
- Corrosion free construction
- Easy to roll construction
- Fast installation
- Utilizes the structure of existing shelving
- Complies with ADA regulations
- 1,500 lb. load capacity per unit
- Can increase storage areas up to 150%



SYSTEMS SLIDE BACK AND FORTH WITH EASE

**QESTP**

**End Stop Kit**

Includes 2 ends and 1 drill bit. Serves the dual purpose of stopping a skate and is the anchor for the track. Manufactured from shock absorbing polymer. One kit is required per track.

**QVTRK**

**V-Groove Track**

Aluminum design with 304 stainless steel inserts with a gradual taper, non-tripping hazard, 7/16" max height. (Sold by the inch)

**HD18 - HD36**

**One Skate**

Aluminum with engineered plastic wheel housing and industrial 2,000 lb. bearings on each end.

**WK**  
**Wing Kit**

Includes four 1/4" thick aluminum plates and hardware and allows for the joining of 2 units side by side, sharing one track.

**SK**  
**Shim Kit**

48"L thick aluminum strips which can be placed underneath track to help create a level surface. (6 per kit)

MODEL NO.	DESCRIPTION	SHIP WGT
<b>Sliding Track Skates</b>		
HD18	One 18" Skate	4 lbs
HD21	One 21" Skate	5 lbs
HD24	One 24" Skate	6 lbs
HD30	One 30" Skate	7 lbs
HD36	One 36" Skate	8 lbs
<b>Additional Components</b>		
QESTP	End Stop Kit	1 lb
QVTRK	V-Track (Sold per inch)	1 lb
WK	Wing Kit	2 lbs
SK*	Shim Kit	3 lbs

\*Shim kit comes with (6) 2" x 48" x 1/16" thick aluminum strips which can be placed underneath track to help create a level surface

**STEP BY STEP ORDERING INSTRUCTIONS:**

(Note: Shelves and posts to be purchased separately)

- Step 1.** Select desired length (in inches) of track. Use **QVTRK** to order track. (Note: single units require two tracks and double units will require three tracks)
- Step 2.** Select corresponding skate size from the chart, which will be the same as the depth of shelving unit to be utilized. Two skates required per single unit and three skates required per double unit. (Note: post height should not exceed a 4 to 1 ratio of skate size)
- Step 3.** Purchase one End Stop Kit **QESTP** per track length. For each double unit being used, a Wing Kit **WK** is required.

**SINGLE UNIT TRACK SYSTEM**  
(Top View)

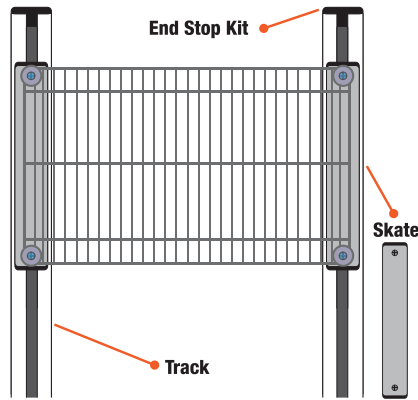

**DOUBLE UNIT TRACK SYSTEM**  
(Top View)

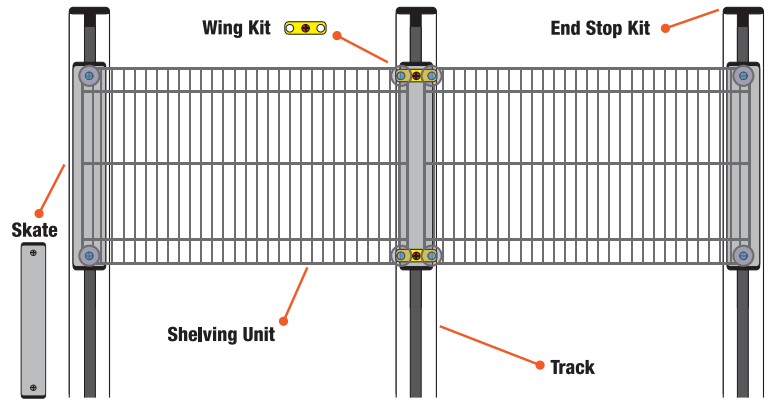

**Single Unit Floor Track Assemblies**



Assembly kit consists of a pair of aluminum tracks with end stop kits. Hardware and assembly instructions included. **(Note: custom lengths may be purchased)**

MODEL NO.	TRACK L' (FT)	TRACK L' (IN)	SHIP WGT
<b>Single Unit Floor Track Assembly Kit</b> Includes 2 Tracks of Specified Length with End Stop Kits			
QVTRK-2-72EST	6'	72"	14 lbs
QVTRK-2-84EST	7'	84"	16 lbs
QVTRK-2-96EST	8'	96"	18 lbs
QVTRK-2-108EST	9'	108"	20 lbs
QVTRK-2-120EST	10'	120"	22 lbs
QVTRK-2-132EST	11'	132"	24 lbs
QVTRK-2-144EST	12'	144"	26 lbs
QVTRK-2-156EST	13'	156"	28 lbs
QVTRK-2-168EST	14'	168"	30 lbs
QVTRK-2-180EST	15'	180"	32 lbs
QVTRK-2-192EST	16'	192"	34 lbs
QVTRK-2-204EST	17'	204"	36 lbs
QVTRK-2-216EST	18'	216"	38 lbs
QVTRK-2-228EST	19'	228"	40 lbs
QVTRK-2-240EST	20'	240"	42 lbs

**1,500 lb.**  
**SLIDE LOAD CAPACITY**  
**PER SHELVING UNIT**

**STEP BY STEP ORDERING INSTRUCTIONS:**

- Select desired length of track and if you require:
  - Single Unit track (use charts on left)
  - Double Unit track (use charts on right)
- Select corresponding skate size from single or double unit charts below. Skate size should match the depth of shelving unit being utilized.
- Using the chart on the bottom of this page, determine how many shelving units will fit on your track.
- Pre-configured 4 and 5 shelf wire units are available. Additional intermediate shelves are available.

**Double Unit Floor Track Assemblies**



Each assembly kit consists of three aluminum tracks with end stop kits. Hardware and assembly instructions included. **(Note: custom lengths may be purchased)**

MODEL NO.	TRACK L' (FT)	TRACK L' (IN)	SHIP WGT
<b>Double Unit Floor Track Assembly Kit</b> Includes 3 Tracks of Specified Length with End Stop Kits			
QVTRK-3-72EST	6'	72"	21 lbs
QVTRK-3-84EST	7'	84"	24 lbs
QVTRK-3-96EST	8'	96"	27 lbs
QVTRK-3-108EST	9'	108"	30 lbs
QVTRK-3-120EST	10'	120"	33 lbs
QVTRK-3-132EST	11'	132"	36 lbs
QVTRK-3-144EST	12'	144"	39 lbs
QVTRK-3-156EST	13'	156"	42 lbs
QVTRK-3-168EST	14'	168"	45 lbs
QVTRK-3-180EST	15'	180"	48 lbs
QVTRK-3-192EST	16'	192"	51 lbs
QVTRK-3-204EST	17'	204"	54 lbs
QVTRK-3-216EST	18'	216"	57 lbs
QVTRK-3-228EST	19'	228"	60 lbs
QVTRK-3-240EST	20'	240"	63 lbs

**Single Unit Skate Assembly Kits**



Each kit includes two skates and all appropriate hardware. One kit is required for each single mobile unit. *(Shelves and posts sold separately)*

MODEL NO.	DESCRIPTION	SHIP WGT
<b>Single Unit Skate Assembly Kits</b>		
HD18-2	Two 18" Skates	8 lbs
HD21-2	Two 21" Skates	10 lbs
HD24-2	Two 24" Skates	12 lbs
HD30-2	Two 30" Skates	14 lbs
HD36-2	Two 36" Skates	16 lbs

**Double Unit Skate Assembly Kits**



Each kit includes three skates and all appropriate hardware. One kit is required for each double mobile unit. *(Shelves and posts sold separately)*

MODEL NO.	DESCRIPTION	SHIP WGT
<b>Double Unit Skate Assembly Kits</b>		
HD18-3	Three 18" Skates + Wing Kit	15 lbs
HD21-3	Three 21" Skates + Wing Kit	18 lbs
HD24-3	Three 24" Skates + Wing Kit	21 lbs
HD30-3	Three 30" Skates + Wing Kit	24 lbs
HD36-3	Three 36" Skates + Wing Kit	27 lbs

**QUANTITY OF SHELVING UNITS BY WIDTH TO FIT ON LENGTH OF TRACK\***

	6'	7'	8'	9'	10'	11'	12'	13'	14'	15'	16'	17'	18'	19'	20'
18"	2	2	3	4	4	5	6	6	7	8	8	9	10	10	11
21"	1	2	2	3	4	4	5	5	6	6	7	8	8	9	9
24"	1	2	2	3	3	4	4	5	5	6	6	7	7	8	8
30"	1	1	2	2	2	3	3	4	4	4	5	5	6	6	6
36"	1	1	1	2	2	2	3	3	3	4	4	4	5	5	5

\*Using a minimum 36" aisle space **Note:** Post height should not exceed the skate length by a 4 to 1 ration (example 18" skate should not exceed a 74" post)