

TECH DATA

RAIL SYSTEMS

RECESSED & SURFACE MOUNT RAILS for ActivRAC[®] Mobilized Storage System - 7M SS (Stainless Steel) Series

Spacesaver's stainless steel recessed and surface mount rails provide a dual-flange 17-4PH stainless steel rail, providing even distribution of heavy loads and precision alignment for long term, easy carriage operation under heavy cyclic load.* Allowing for recessed or surface-mounted rail installation.

DESIGN BENEFITS AND CAPABILITIES

- **Recessed Rail** – Low-profile 3/8" (9.5 mm) high x 4.00" (101.6 mm) wide steel rails. Installed flush with concrete surface.
- **Surface Mount Rail** – Low-profile 3/8" (9.5 mm) high x 4-1/2" (114 mm) wide steel rails with beveled edges. Rails are ADA compliant.
- Provides minimal interruption of material handling equipment
- Supports up to 7,000 lbs. (3,175 kg) per wheel assembly
- Disperses heavy wheel loads to floor.
- Designed to operate under heavy, long-term, cyclic stress loads.

- Provides the solid basic foundation required for heavy-duty mobilized storage systems, assuring low maintenance and easy operation.

FLOOR REQUIREMENTS

- Rail and carriage design allows concrete slab to be leveled to following maximum variation:
 - » 3/16" (4.8 mm) maximum variation over any 2' (.6 m) rail run.
 - » 1/4" (6.4 mm) maximum variation over any 10' (3.04 m) rail run.
 - » 1/4" (6.4 mm) maximum variation between adjacent rails.

RECESSED RAIL

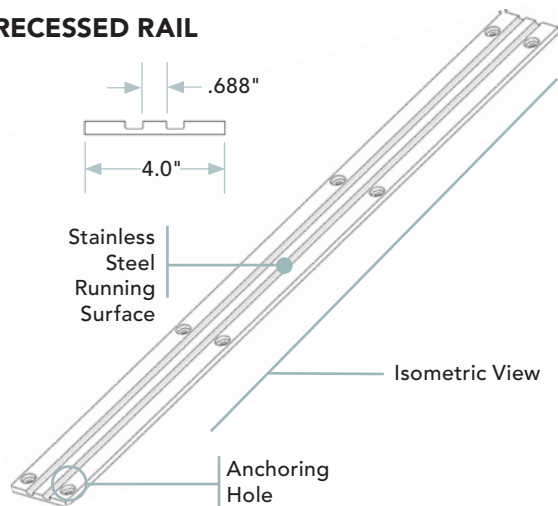

SURFACE MOUNT RAIL

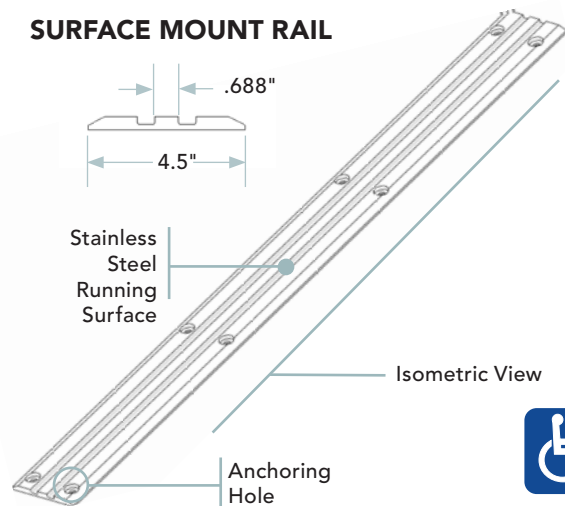

ADA Compliant

*Cyclic load stresses are the weight and forces placed on all parts of a mobile system as it cycles back and forth and as it rests. The force of movement combined with the weight of the stored materials is transferred to the storage housing and down the storage housing's vertical members to the carriage, represents the cyclic load stress on the carriage. From the carriage, the load is transferred to the bearing/axle/wheel assembly where it becomes a point load that is then transferred to the system's rails, and finally floor.

INSTALLATION

Position the rail sections in their relative location where the completed mobile system will be used. Once positioned, drill holes in the floor through the anchor holes. **RECESSED RAILS:** Will require saw cutting into floor and high strength epoxy under rail. Stagger joints across adjacent rail runs. **SURFACE MOUNT:** Secure rails directly to floor with anchor screws. (Anchor screws, saw cutting and high strength epoxy are supplied by the local Spacesaver Area Contractor).

RECESSED RAIL

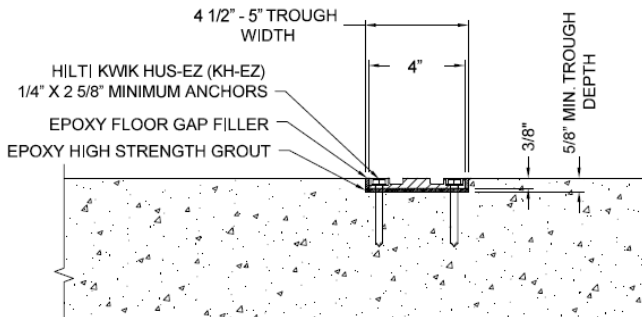

SURFACE MOUNT RAIL

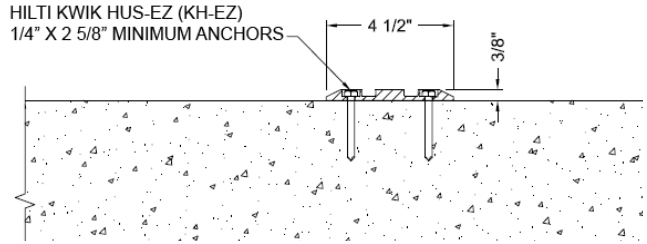

APPLICATION

This surface mount or recessed rail is compatible with ActivRAC 7M & 7P mechanical assist and powered mobile storage systems which utilize dual-flange guidance.

TECHNICAL SPECIFICATIONS

RAIL:

Recessed Rail shall be 17-4PH stainless steel bar 4.00" (101.6 mm) wide x 3/8" (9.5 mm) high. Rail shall disperse the wheel line loads to structural slab. Rail shall have two permanently mounted floor anchors maximum 15" (381 mm) on center. Rails shall be installed flush with concrete slab.

Surface Mount Rail shall be 17-4PH stainless steel bar 4-1/2" (114 mm) wide x 3/8" (9.5 mm) high. Rail edges shall be beveled down to a maximum of 3/16" (4.8 mm) to allow for the rail to be transversed by material handling equipment. Rail shall disperse the wheel line loads to structural slab. Rail shall have two permanently mounted floor anchors maximum 15" (381 mm) on center.

Rails shall be installed on top of concrete slab. Rail and carriage design allows concrete slab to be unlevel at the following maximum variations:

- 3/16" (4.8 mm) maximum variation over any 2' (.6 m) rail run.
- 1/4" (6.4 mm) maximum variation over any 10' (3.04 m) rail run.
- 1/4" (6.4 mm) maximum variation between adjacent rails.

Specifications are subject to change.